	<b>Technical Specification for Type Approval of Water Meters</b>		S/N	CNPA 49																																					
			Rev	4																																					
<p>1. This Technical Specification is developed pursuant to Paragraph 3, Articles 25 of the Weights and Measures Act.</p> <p>2. The date of promulgation, document number, date of enforcement and content of amendment are listed as follows:</p> <table border="1"> <thead> <tr> <th>Rev.</th> <th>Date of Promulgation</th> <th>Document No. (Ching-Piao-Szu-Tsu )</th> <th>Date of Enforcement</th> <th>Content of Amendment</th> </tr> </thead> <tbody> <tr> <td>1</td> <td>12.06.2003</td> <td>No. 09240005480</td> <td>07.01.2003</td> <td></td> </tr> <tr> <td>2</td> <td>08.12.2005</td> <td>No. 09440004630</td> <td>07.01.2006</td> <td>Revised according to CNS 14866</td> </tr> <tr> <td>3</td> <td>11.03.2014</td> <td>No. 10340009830</td> <td>01.01.2015</td> <td>Due to the CNS could be revised when correspondence international standards or recommendation revised, third edition will no longer refer to CNS. In addition, there are appendixes added to this edition.</td> </tr> <tr> <td>4</td> <td>00.00.2022</td> <td>No. 0000000000</td> <td>07.01.2023</td> <td>Revised with reference to OIML R49: 2013</td> </tr> </tbody> </table> <p>3. The reference standards of this technical specification are as follows:</p> <table border="1"> <tbody> <tr> <td>CNS14866-1</td> <td>Measurement of water flow in closed conduits-Meters for cold potable water-Part 1: Specification (Oct 20, 2004)</td> </tr> <tr> <td>CNS14866-2</td> <td>Measurement of water flow in closed conduits-Meters for cold potable water-Part 2: Installation requirements and Selection (Oct 20, 2004)</td> </tr> <tr> <td>CNS14866-1</td> <td>Measurement of water flow in closed conduits-Meters for cold potable water-Part 1: Test Methods and Equipment (Oct 20, 2004)</td> </tr> <tr> <td>CNS 13979</td> <td>Vortex Flow Meter (Jun 28, 1999)</td> </tr> <tr> <td>OIML R49-1:2013</td> <td>Water meters for cold potable water and hot water. Part 1: Metrological and technical requirements</td> </tr> <tr> <td>OIML R49-2:2013</td> <td>Water meters for cold potable water and hot water. Part 2: Test methods</td> </tr> </tbody> </table>					Rev.	Date of Promulgation	Document No. (Ching-Piao-Szu-Tsu )	Date of Enforcement	Content of Amendment	1	12.06.2003	No. 09240005480	07.01.2003		2	08.12.2005	No. 09440004630	07.01.2006	Revised according to CNS 14866	3	11.03.2014	No. 10340009830	01.01.2015	Due to the CNS could be revised when correspondence international standards or recommendation revised, third edition will no longer refer to CNS. In addition, there are appendixes added to this edition.	4	00.00.2022	No. 0000000000	07.01.2023	Revised with reference to OIML R49: 2013	CNS14866-1	Measurement of water flow in closed conduits-Meters for cold potable water-Part 1: Specification (Oct 20, 2004)	CNS14866-2	Measurement of water flow in closed conduits-Meters for cold potable water-Part 2: Installation requirements and Selection (Oct 20, 2004)	CNS14866-1	Measurement of water flow in closed conduits-Meters for cold potable water-Part 1: Test Methods and Equipment (Oct 20, 2004)	CNS 13979	Vortex Flow Meter (Jun 28, 1999)	OIML R49-1:2013	Water meters for cold potable water and hot water. Part 1: Metrological and technical requirements	OIML R49-2:2013	Water meters for cold potable water and hot water. Part 2: Test methods
Rev.	Date of Promulgation	Document No. (Ching-Piao-Szu-Tsu )	Date of Enforcement	Content of Amendment																																					
1	12.06.2003	No. 09240005480	07.01.2003																																						
2	08.12.2005	No. 09440004630	07.01.2006	Revised according to CNS 14866																																					
3	11.03.2014	No. 10340009830	01.01.2015	Due to the CNS could be revised when correspondence international standards or recommendation revised, third edition will no longer refer to CNS. In addition, there are appendixes added to this edition.																																					
4	00.00.2022	No. 0000000000	07.01.2023	Revised with reference to OIML R49: 2013																																					
CNS14866-1	Measurement of water flow in closed conduits-Meters for cold potable water-Part 1: Specification (Oct 20, 2004)																																								
CNS14866-2	Measurement of water flow in closed conduits-Meters for cold potable water-Part 2: Installation requirements and Selection (Oct 20, 2004)																																								
CNS14866-1	Measurement of water flow in closed conduits-Meters for cold potable water-Part 1: Test Methods and Equipment (Oct 20, 2004)																																								
CNS 13979	Vortex Flow Meter (Jun 28, 1999)																																								
OIML R49-1:2013	Water meters for cold potable water and hot water. Part 1: Metrological and technical requirements																																								
OIML R49-2:2013	Water meters for cold potable water and hot water. Part 2: Test methods																																								
<b>Date of Promulgation</b> <b>00.00.2021</b>	<b>Bureau of Standards, Metrology and Inspection,</b> <b>Ministry of Economic Affairs</b>		<b>Date of Enforcement</b> <b>07.01.2023</b>																																						

**NO GUARANTEE ON THE TRANSLATION**

In case of discrepancies between the English translation and Chinese text, the Chinese text shall govern.

## 1. Scope

- 1.1 This technical specification applies to cold potable water meters based on mechanical principle, electrical or electronic principle, and mechanical principles incorporating electronic devices, used to measure the volume of cold potable water, but not applies to water meters for fire protection.
- 1.2 The applicable conditions of the above water meter are as follows:
  - 1.2.1 The connection method shall be to screw type or flange type, and its inlet and outlet located on both sides of the water meter.
  - 1.2.2 Nominal diameter range is from 13 mm to 300 mm.
  - 1.2.3 Permanent flow rate is from 1.6 m<sup>3</sup>/h to 1000 m<sup>3</sup>/h.
  - 1.2.4 The value of the ratio of permanent flow rate to minimum flow rate is from 50 to 400 (Vortex meter is suitable from 10 to 40).
  - 1.2.5 The maximum admissible pressure is equal to or less than 1 MPa.
- 1.3 Ancillary devices do not belong to the scope of type approval, but the relevant regulations of the Weights and Measures Act stipulate otherwise.

## 2. Definitions of Terms

### 2.1 Water meter

Instrument intended to measure continuously, memorize, and display the volume of water passing through the measurement transducer at metering conditions. The indicating device and the water meter shall be inseparable.

#### 2.1.1 Volumetric meter

Device, fitted into a closed conduit, which consists of chambers of known volume and a mechanism driven by the flow, whereby these chambers are successively filled with water and then emptied. By counting the number of these volumes passing through the device, the indicating device totals the volume flow.

#### 2.1.2 Velocity meter

Device, fitted into a closed conduit which consists of a moving element set in motion directly by the velocity of the water flow. The movement of the moving element is transmitted by mechanical or other means to the indicating device, which totals the volume flow.

#### 2.1.3 Woltmann meter

Device consisting of a helical blade that rotates about the axis of flow in the meter.

#### 2.1.4 Single-jet and multi-jet meters

Devices consisting of a turbine rotor rotating about the axis perpendicular to the flow of water in the meter. The meter is called a single-jet meter if the jet impinges at a single place on the rotor's periphery, and a multi-jet if the jet impinges simultaneously at several points around the periphery of the rotor.

#### 2.1.5 Vortex meters

Devices comprising a bluff body in the water flow to detect the vortices frequency after the bluff body continuously and integrating an indicator which total the volume flow.

### 2.2 Sensor

Element of a meter that is directly affected by a phenomenon, body or substance carrying a quantity to be measured (For a water meter, the sensor may be a disc, piston, wheel or turbine element, the electrodes on an electromagnetic meter, or another element).

### 2.3 Calculator

Part of the meter that transforms the output signals from the measurement transducer(s) and, possibly, from associated measuring instruments and, if appropriate, stores the results in memory until they are used.

The gearing is considered to be the calculator in a mechanical meter.

The calculator may be capable of communicating both ways with ancillary devices.

### 2.4 Indicating device

Device displaying the volume flowing.

### 2.5 Ancillary device

Device intended to perform a specific function, directly involved in elaborating, transmitting or displaying measured values, but is not a device necessary for a water meter.

The main ancillary devices are

- repeating indicating device;
- memory device;
- remote reading device (which may be incorporated permanently or added temporarily).

### 2.6 Metrological characteristics

#### 2.6.1 Actual volume, $V_a$

Total volume of water passing through the meter, disregarding the time taken. The actual volume is calculated from a reference volume as determined by a suitable measurement standard, taking into account differences in metering conditions, as appropriate.

#### 2.6.2 Indicated volume, $V_i$

Volume of water indicated by the meter, corresponding to the actual volume.

#### 2.6.3 Primary indication

Indication which is subject to legal metrological control.

#### 2.6.4 Error

Measured quantity value minus a reference quantity value. The indicated volume is considered as the measured quantity value and the actual volume as the reference quantity value. The difference between indicated volume and actual volume is referred to as: error.

In this Technical Specification, the error (of indication) is expressed as a percentage of the actual volume, and is equal to

$$\frac{V_i - V_a}{V_a} \times 100\%$$

#### 2.6.5 Maximum permissible error, MPE

Extreme value of measurement error, with respect to a known reference quantity value, permitted by specifications or regulations for a given meter.

#### 2.6.6 Durability

Ability of a meter to maintain its performance characteristics over a period of use.

## 2.7 Operating conditions

### 2.7.1 Flow rate, $Q$

$Q = dV/dt$  where  $V$  is actual volume and  $t$  is time taken for this volume to pass through the meter. The flow rate is expressed in  $m^3/h$ .

### 2.7.2 Permanent flow rate, $Q_3$

Highest flow rate within the rated operating conditions at which the meter is to operate within the maximum permissible errors.

### 2.7.3 Overload flow rate, $Q_4$

Highest flow rate at which the meter is to operate for a short period of time within the maximum permissible errors, while maintaining its metrological performance when it is subsequently operating within the rated operating conditions.

### 2.7.4 Transitional flow rate, $Q_2$

Flow rate between the permanent flow rate and the minimum flow rate that divides the flow rate range into two zones, the upper flow rate zone ( $Q_2 \leq Q \leq Q_4$ ) and the lower flow rate zone ( $Q_1 \leq Q < Q_2$ ), each characterized by its own maximum permissible errors.

### 2.7.5 Minimum flow rate, $Q_1$

Lowest flow rate at which the meter is to operate within the maximum permissible errors.

### 2.7.6 First element of an indicating device

Element which, in an indicating device comprising several elements, carries the graduated scale with the verification scale interval.

### 2.7.7 Verification scale interval

Lowest value scale division of the first element of an indicating device.

### 2.7.8 Maximum admissible pressure, MAP

Maximum internal pressure that a meter can withstand permanently, within its rated operating conditions, without deterioration of its metrological performance.

### 2.7.9 Working pressure, $p_w$

Average water pressure (gauge) in the pipe measured upstream and downstream of the meter.

### 2.7.10 Pressure loss, $\Delta_p$

Pressure loss caused by the presence of a water meter in the pipeline at a given flowrate.

### 2.7.11 Nominal diameter, DN

Alphanumeric designation of size for components of a pipework system, which is used for reference purposes.

The nominal diameter is a dimensionless whole number which is indirectly related to the physical size, in millimetres, of the bore or outside diameter of the end connections.

### 2.7.12 Nominal pressure, PN

Numerical designation which is a rounded number for reference purposes. All equipment of the same nominal size (DN) and designated by the same PN number shall have compatible mating dimensions.

### 2.7.13 Intrinsic error

Error of a meter determined under reference conditions.

## 2.7.14 Initial intrinsic error

Intrinsic error of a meter as determined prior to performance tests and durability evaluations.

## 2.7.15 Fault

Difference between the error (of indication) and the intrinsic error of a meter.

## 2.7.16 Significant fault

Fault greater than a value equal to one half of the MPE.

## 3. Metrological requirements

3.1 Values of  $Q_1$ ,  $Q_2$ ,  $Q_3$ , and  $Q_4$ 

3.1.1 The flow rate characteristics of a water meter shall be defined by the values of  $Q_1$ ,  $Q_2$ ,  $Q_3$ , and  $Q_4$ .

3.1.2 The value of  $Q_3$ , expressed in  $\text{m}^3/\text{h}$ , shall be chosen from the following list:

1.6	2.5	4	6.3	10
16	25	40	63	100
160	250	400	630	1000

3.1.3 The value of the ratio  $Q_3/Q_1$  shall be chosen from the following list: (Among them, values  $\leq 40$  are only applicable to the vortex flow meter)

10	12.5	16	20	25
31.5	40	50	63	80
100	125	160	200	250
315	400			

3.1.4 The ratio  $Q_2/Q_1$  shall be 1.6.

3.1.5 The ratio  $Q_4/Q_3$  shall be 1.25.

## 3.2 Accuracy class and maximum permissible error

The water meter shall be designed and manufactured such that its errors (of indication) do not exceed the maximum permissible errors (MPEs) as defined in Table 1 under rated operating conditions. The accuracy class is classified as class 1 or class 2. The manufacturer shall specify the accuracy class.

Table 1 Accuracy grades and tolerances

flow rate	MPE	
	class 1	class 2
$Q_1 \leq Q < Q_2$	$\pm 3 \%$	$\pm 5 \%$
$Q_2 \leq Q \leq Q_4$	$\pm 1 \%$	$\pm 2 \%$

### 3.3 Reverse flow

The manufacturer shall specify whether or not a water meter is designed to measure reverse flow.

If a meter is designed to measure reverse flow, the design of its water meter shall adopt one of the following two methods:

- (a) the volume passed during reverse flow shall either be subtracted from the indicated volume or
- (b) provide a indicating device for reverse flow. In this case, the  $Q_3$  of the indicating device for forward flow is different from that of the indicating device for reverse flow.

If a meter is not designed to measure reverse flow, the design of its water meter shall adopt one of the following two methods:

- (c) there is a design to force the occurrence of reverse flow or
- (d) it shall withstand accidental reverse flow at a flow rate up to  $Q_3$  without deterioration or change in its metrological properties for forward flow.

3.4 The water meter totalization shall not change in the absence either of flow or of water.

3.5 Static pressure: A water meter shall be capable of withstanding the following test pressures without leakage or damage.

- (a) 1.6 times the maximum admissible pressure applied for 15 min;
- (b) twice the maximum admissible pressure applied for 1 min.

### 3.6 Flow profile sensitivity

The flow field sensitivity of the water meter is tested with a flow disturber (Appendix A), and its classification is shown in Table 2 and Table 3. A meter manufacturer shall specify the flow profile sensitivity class in accordance with Tables 2 and 3.

Table 2 Sensitivity to irregularity in the upstream velocity field classes (U)

Class	Required straight length $\times$ DN	Straight ener needed
U0	0	No
U3	3	No
U5	5	No
U10	10	No
U15	15	No
U0S	0	yes
U3S	3	yes
U5S	5	yes
U10S	10	yes

Table 3 Sensitivity to irregularity in the downstream velocity fields classes (D)

Class	Required straight length xDN	Straight ener needed
D0	0	No
D3	3	No
D5	5	No
D0S	0	yes
D3S	3	yes

Note: Sensitivity level symbol

UXS: U means upstream, D means downstream, X means pipe diameter multiple, and S means rectifier required

Example: U5S upstream straight pipe 5 times, need Straightener,  
 D3 downstream straight pipe 3 times, no Straightener.

4. Water meters equipped with electronic devices

4.1 A water meter equipped with electronic devices shall be designed and manufactured in such a way that exceed the MPE of the upper zone or significant faults do not occur when it is exposed to the disturbances specified in Section 8.

4.2 The power source can be external power supply, non-replaceable battery and replaceable battery.

4.3 External power supply

4.3.1 A water meter with electronic devices shall be designed such that in the event of an external power supply failure (AC or DC), the meter indication of volume just before failure is not lost, and remains accessible for a minimum of one year.

The corresponding memorization shall occur at least either once per day or for every volume equivalent to 10 min of flow at  $Q_3$ .

Any other properties or parameters of a meter shall not be affected by an interruption of the power supply.

4.4 The manufacturer shall ensure that the expected lifetime of the non-replaceable battery is such that a meter functions correctly for at least one year longer than the operational lifetime of the meter. A low battery or exhausted battery indicator or a meter replacement date shall be indicated on the meter.

If the register display gives an indication of “low battery”, there shall be at least 180 days of useful life for the register display from the time “low battery” indication is displayed to end of life.

4.5 Where the electrical power supply is a replaceable battery, the manufacturer shall give precise rules for the replacement of the battery.

A low battery or exhausted battery indicator or a battery replacement date shall be indicated on the meter. If the register display gives an indication of “low battery”, there shall be at least 180 days of useful life for the register display from the time “low battery” indication is displayed to end of life.

The properties and parameters of a meter shall not be affected by the interruption of the electrical supply when the battery is replaced.

When replacing the battery, the seal shall be destroyed.

## 5. Technical requirements

5.1 All parts of a water meter in contact with the water flowing through it shall be manufactured from materials which are conventionally known to be non-toxic, non-contaminating, and biologically inert. The materials shall be determined by the water utility agencies and identified the requirements in the procurement specifications.

5.2 A water meter shall be manufactured from materials of adequate strength and durability for the purpose for which it is to be used.

5.3 A water meter shall be manufactured from materials which shall not be adversely affected by the water temperature variations, within the working temperature range.

5.4 The complete water meter shall be manufactured from materials which are resistant to internal and external corrosion or which are protected by a suitable surface treatment.

5.5 A water meter indicating device shall be protected by a transparent window. A cover of a suitable type may also be provided as additional protection.

### 5.6 Structure

5.6.1 The meter size and overall dimensions of volumetric and velocity water meters shall be in accordance with Appendix B

5.6.2 The meter size and overall dimensions of vortex water meters shall be in accordance with Appendix C.

5.7 The transparent lid of a water meter shall be transparent and clear, and must not be loosened when pressed by hand.

The top lid of the water meter shall be opened equal to or more than 120 degrees.

5.8 Volumetric and velocity multi-jet meters shall be equipped with appropriate strainers at the inlet.

5.9 After verified and sealed, the measurement errors or zero-setting of water meters shall not be able to be adjusted by external methods or devices. If the meter is provided with a zero-setting device for special purposes, the zeroing position shall be zeroed upon operation, but the totaling device shall not be zeroed.

5.10 The shell of a water meter should not be coated with wax, soluble glass or any other leak proof material; the shell of a water meter should be free of sags, crests, scratches or any traces of repair. A position shall be reserved for the lead seal.

However, the interior and exterior of the shell of a big water meter with a nominal size of not less than 50 mm may be coated with rustproof paint or powder coating.

5.11 Where there is a risk of condensation forming on the underside of the window of a water meter



indicating device, the water meter shall incorporate devices for prevention or elimination of condensation.

5.12 A water meter shall be of such design, composition, and construction that it does not facilitate the perpetration of fraud.

5.13 Marks and inscriptions

5.13.1 The water meter size should be marked on the lid exterior center and the side of water meter.

5.13.2 The direction of flow ( $\rightarrow$ ) shall be marked on both sides of the water meter.

5.13.3 Name or trademark of the manufacturer shall be marked on one side of water meter exterior or on the indicating device.

5.13.4 The serial number should be marked on the edge of meter exterior.

5.13.5 The indication range (maximum capacity of accumulation) and numbers of meter shall be marked on the indicating device.

5.13.6 The model number shall be marked on the indicating device clearly.

5.13.7 A position for marking the type approval number shall be reserved in an obvious position on the indicating device.

5.13.8 The validity period of verification shall be marked on the edge of the upper shell.

5.13.9 The water meter shall be installed in the horizontal position. The installation direction(H) shall be marked on both sides of water meter or on the indicating device of water meter. The vortex water meters are excluded.

5.13.10 A water meter shall be clearly and indelibly marked with the information of numerical value of  $Q_3$ , the ratio  $Q_3/Q_1$ , accuracy class, the pressure loss class and nominal pressure. If the meter measures reverse flow and the values of  $Q_3$  and the ratios  $Q_3/Q_1$  are different in the two directions, both values of  $Q_3$  and  $Q_3/Q_1$  shall be inscribed.

5.13.11 The flow profile sensitivity class should be marked in a prominent place.

6. Indicating device

6.1 Functions

The indicating device of a water meter shall provide an easily read, reliable, and unambiguous visual indication of the indicated volume. The indicating device shall display the volume either continuously, periodically or on demand. The indicating device shall include visual means for testing and verification. The indicating device may include additional elements for testing by other methods.

6.2 Unit of measurement, symbol and its placement

The volume of water measured shall be expressed in cubic metres. The unit symbol ( $m^3$ ) shall appear on the dial or immediately adjacent to the numbered display.

6.3 Indicating range

The indicating device shall be able to record the indicated volume in cubic metres given in Table 4 without passing through zero.

Table 4 Indicating range of a water meter

$Q_3, \text{ m}^3/\text{h}$	Indicating range (minimum values), $\text{m}^3$
$Q_3 \leq 6.3$	9 999
$6.3 < Q_3 \leq 63$	99 999
$63 < Q_3 \leq 630$	999 999
$630 < Q_3 \leq 1\ 000$	9 999 999

#### 6.4 Color coding for indicating devices

##### (a) Non-electronic digital indicator

The color black should be used to indicate the cubic metre and its multiples. The color red should be used to indicate sub-multiples of a cubic metre. These colors shall be applied to either pointers, indexes, numbers, wheels, discs, dials or to the aperture frames.

##### (b) Electronic digital indicator

The color black should be used to indicate the cubic metre and its multiples.

#### 6.5 Types of indicating device

Any of the following types shall be used.

##### 6.5.1 Type 1 – Analogue device

The indicated volume is indicated by continuous movement of

- (a) one or more pointers moving relative to graduated scales, or
- (b) one or more circular scales or drums each passing an index.

The value expressed in cubic metres for each scale division shall be of the form  $10^n$ , where  $n$  is a positive or negative whole number or zero, thereby establishing a system of consecutive decades. Each scale shall either be:

- graduated in values expressed in cubic metres
- or accompanied by a multiplication factor ( $\times 0.001$ ;  $\times 0.01$ ;  $\times 0.1$ ;  $\times 1$ ;  $\times 10$ ;  $\times 100$ ;  $\times 1\ 000$ , etc.)

Rotational movement of the pointers or circular scales shall be clockwise. Linear movement of pointers or scales shall be left to right. Movement of numbered roller indicators (drums) shall be upwards.

##### 6.5.2 Type 2 – Digital device

The indicated volume is given by a line of adjacent digits appearing in one or more apertures.

The advance of a given digit shall be completed while the digit of the next immediately lower decade changes from 9 to 0. The apparent height of the digits shall be at least 4 mm.

- (a) For non-electronic devices: Movement of numbered roller indicators (drums) shall be upwards. If the lowest value decade has a continuous movement, the aperture shall be large enough to permit a digit to be read unambiguously.
- (b) For electronic devices: Either permanent or non-permanent displays are permitted. For non-permanent displays, the volume shall be able to be displayed at any time for at least 10 s. The meter shall provide visual checking of the entire display which shall have the following sequence:
  - for seven segment type displaying all the elements (e.g. an “eights” test);
  - for seven segment type blanking all the elements (a “blanks” test);
  - for graphical displays an equivalent test to demonstrate that display faults cannot result in any digit being misinterpreted.

Each step of the sequence shall last at least 1 s.

#### 6.5.3 Type 3 – Combination of analogue and digital devices

The indicated volume is given by a combination of type 1 and type 2 devices and the respective requirements of each shall apply.

#### 6.5.4 Verification scale interval

6.5.4.1 Every indicating device shall provide means for visual, non-ambiguous verification testing. The visual verification display may have either a continuous or a discontinuous movement.

##### 6.5.4.2 Verification Scale Interval

The indicator element with the smallest decimal number, and its smallest decimal scale value is called the verification scale interval. In addition to the visual verification display, an indicating device may include provisions for rapid testing by the inclusion of complementary elements (e.g. star wheels or discs), providing signals through externally attached sensors and convert the recorded data into numerical data.

6.5.4.3 The value of the verification scale interval expressed in cubic metres shall be of the form:  $1 \times 10^n$ ,  $2 \times 10^n$  or  $5 \times 10^n$ , where  $n$  is a positive or negative whole number, or zero. For analogue and digital indicating devices with continuous movement of the first element, the verification scale may be formed from the division into 2, 5 or 10 equal parts of the interval between two consecutive digits of the first element. Numbering shall not be applied to these divisions.

##### 6.5.4.4 Form of the verification scale

- (a) On indicating devices with continuous movement of the first element, the apparent scale spacing shall be not less than 1 mm and not more than 5 mm.
- (b) On indicating devices with non-continuous movement of the first element, the verification scale interval is the interval between two consecutive digits or incremental movements of the first element.

6.5.5 The minimum verification scale of the indicating device shall meet the requirements in Table

5.

Table 5 Minimum subdivisions value

Accuracy	continuous	discontinuous,
Class 1	$1.5Q_1 \times 0.25\%$	$1.5Q_1 \times 0.125\%$
Class 2	$1.5Q_1 \times 0.5\%$	$1.5Q_1 \times 0.25\%$

(a) If the minimum verification scale is continuous, an allowance shall be made for a maximum error in each reading of not more than half the verification scale interval.

(b) If the minimum verification scale is discontinuous, an allowance shall be made for a maximum error in each reading of not more than one digit of the verification scale.

## 7. Performance test

7.1 The evaluation tests shall be made on the minimum number of samples of each type shown in Table 6 as a function of the water meter designation  $Q_3$  of the type presented. The authority responsible for type approval may request further specimens.

For type approval of a water meter with electronic devices, five samples shall be supplied for the tests specified in Section 8, which may be different samples from those supplied for other testing, with at least one meter being subjected to all the appropriate tests. The same meter shall be subjected to all testing.

Table 6 Minimum number of water meters to be tested

Meter designation, $Q_3$ $\text{m}^3/\text{h}$	Minimum number of meters to be tested for all meter types, excluding the tests required for meters with electronic devices
$Q_3 \leq 160$	3
$160 < Q_3 \leq 1,000$	2

7.2 Meters are tested either individually or in groups. In the latter case, the straight lengths between the meters shall be enough. The presence of any meter in the test rig shall not contribute significantly to the test error of any other meter. During the tests, the gauge pressure at the outlet of each water meter shall be at least 0.03 MPa (0.3 bar).

## 7.3 Static pressure

A water meter shall be capable of withstanding the following test pressures without leakage or damage:

7.3.1 1.6 Times the maximum admissible pressure applied for 15 min and twice the maximum admissible pressure applied for 1 min.

## 7.3.2 Acceptance criteria

There shall be no leakage from the meter or physical damage. For a water meter with a dry indicating device, water should not be immersed in the upper gear chamber and the indicating device.

## 7.4 Errors (of indication)

## 7.4.1 Test method

It can be the volume method, the weighing method or the standard table method. The

expanded uncertainty of the equipment used shall not exceed one-fifth of the MPE, and the coverage factor of the estimated uncertainty is  $k=2$ .

#### 7.4.2 Flow rate

Determine the intrinsic errors (of indication) of a water meter (in the measurement of the actual volume), for at least the following flow rates, the error at each flow rate being measured three times for (a), (b) and (e) and twice for the other flow rate ranges. The relative errors (of indication) observed for each of the flow rates shall not exceed the maximum permissible errors given in Table 1 in section 3.2.

- (a)  $Q_1$  to  $1.1 Q_1$ ;
- (b)  $Q_2$  to  $1.1 Q_2$ ;
- (c)  $0.33 \times (Q_2 + Q_3)$  to  $0.37 \times (Q_2 + Q_3)$ ;
- (d)  $0.67 \times (Q_2 + Q_3)$  to  $0.74 \times (Q_2 + Q_3)$ ;
- (e)  $0.9 Q_3$  to  $Q_3$ ;
- (f)  $0.95 Q_4$  to  $Q_4$ ;

This flow rate variation condition is acceptable if the relative pressure variation (in flow to free air) or the relative variation of pressure loss (in closed circuits) does not exceed:

$\pm 5$  % from  $Q_1$  to  $Q_2$  (exclusive);

$\pm 10$  % from  $Q_2$  (inclusive) to  $Q_4$ .

The relative variation in the flow rate during each test (not including starting and stopping) shall not exceed:

$\pm 2.5$  % from  $Q_1$  to  $Q_2$  (exclusive);

$\pm 5.0$  % from  $Q_2$  (inclusive) to  $Q_4$ .

#### 7.4.3 Orientation of water meter(s)

7.4.3.1 Mount the connecting pipework with the flow axis in the horizontal plane during the test (indicating device positioned on top).

7.4.3.2 If the meters are not marked "H" or "V"

- (a) At least one meter from the sample shall be mounted with the flow axis vertical, with flow direction from bottom to top;
- (b) At least one meter from the sample shall be mounted with the flow axis at an intermediate angle to the vertical and horizontal ( $45^\circ$ ) (chosen at the discretion of the body responsible for type approval);
- (c) The remaining meters from the sample shall be mounted with the flow axis horizontal.

7.4.3.3 The tolerance on the position of the flow axis for all meters, whether horizontal, vertical or at an intermediate angle, shall be  $\pm 5^\circ$ .

7.4.4 Where the initial error curve is close to the maximum permissible error at a point other than at  $Q_1$ ,  $Q_2$  or  $Q_3$ , if this error is shown to be typical of the meter type, the body responsible for type approval may choose to define an additional flow rate for verification to be included in

the type approval certificate.

#### 7.4.5 Acceptance criteria

- (a) The relative errors (of indication) observed for each of the flow rates shall not exceed the maximum permissible errors given in Table 1. If the error observed on one or more meters is greater than the maximum permissible error at one flow rate only, then if only two results have been taken at that flow rate, the test at that flow rate shall be repeated; the test shall be declared satisfactory if two out of the three results at that flow rate lie within the maximum permissible error and the arithmetic mean of the results for the three tests at that flow rate lies within the maximum permissible error.
- (b) If all the relative errors (of indication) of a water meter have the same sign, at least one of the errors shall not exceed one-half of the maximum permissible error.
- (c) The standard deviation for section 7.4.2(a), (b) and (c) shall not exceed one-third of the maximum permissible errors.

#### 7.5 Water pressure test

Measure the error (of indication) of at least one meter at a flow rate of  $Q_2$  with the inlet pressure held firstly at 0.03 MPa (0.3 bar)(the test pressure error range is 0 % ~ 5 %) and then at the maximum admissible pressure (MAP)( the maximum allowable pressure does not exceed 1 MPa, and the test pressure error range is -10 % ~ 0 %). The relative errors (of indication) shall not exceed the maximum permissible errors given in Table 1 in section 3.2.

#### 7.6 Reverse flow test

##### 7.6.1 Meters designed to measure reverse flow

Measure the error (of indication) of at least one meter at each of the following reverse flow rate ranges:

- (a)  $Q_1$  to 1.1  $Q_1$ ;
- (b)  $Q_2$  to 1.1  $Q_2$ ;
- (c) 0.9  $Q_3$  to  $Q_3$ .

The relative errors (of indication) shall not exceed the maximum permissible errors given in Table 1 in section 3.2. In addition, the following tests shall be carried out with the application of reverse flow: pressure loss test and durability test.

##### 7.6.2 Meters not designed to measure reverse flow

Subject the meter to a reverse flow of 0.9  $Q_3$  for 1 min. Measure the error (of indication) of at least one meter at the following forward flow rate ranges:

- (a)  $Q_1$  to 1.1  $Q_1$ ;
- (b)  $Q_2$  to 1.1  $Q_2$ ;
- (c) 0.9  $Q_3$  to  $Q_3$ .

Error must meet the requirements in Table 1 in section 3.2.

7.6.3 Meters which prevent reverse flow

Meters which prevent reverse flow should be subjected to the maximum admissible pressure in the reverse flow direction for 1 min. Check that there is no significant leak past the valve. Measure the error (of indication) of at least one meter in the following forward flow rate ranges:

- (a)  $Q_1$  to 1.1  $Q_1$ ;
- (b)  $Q_2$  to 1.1  $Q_2$ ;
- (c) 0.9  $Q_3$  to  $Q_3$ .

Error must meet the requirements in Table 1 in section 3.2..

7.7 Pressure loss test

7.7.1 The pressure loss class is selected by the manufacturer choice from the values in Table 7.

And the water meter is tested for pressure loss as shown in Figure 1. When the pressure loss test value exceeds the maximum value listed in the classification, it is judged to be unqualified.

Table7 Pressure loss classes

Class	Maximum pressure loss	
	MPa	bar
$\Delta p_{63}$	0.063	0.63
$\Delta p_{40}$	0.040	0.40
$\Delta p_{25}$	0.025	0.25
$\Delta p_{16}$	0.016	0.16
$\Delta p_{10}$	0.010	0.10

7.7.2 To determine the maximum pressure loss through a water meter at any flow rate between  $Q_1$  and  $Q_3$ .

7.7.3 The pressure tapping hole can be a round hole or an annular groove. Holes drilled through the pipe wall should be perpendicular to the pipe axis. (refer to Figures 2 and 4). The pressure tapping hole diameter,  $d$ , is equal to  $0.08D$  and is between 2 mm and 4 mm. If the pipe diameter is less than or equal to 25 mm, the tappings should be as close to 2 mm in diameter as possible. The diameter of the holes should remain constant for a distance of not less than twice the tapping diameter before breaking into the pipe. The holes drilled through the pipe wall should be free from burrs at the edges where they break through into the inlet and outlet pipe bores. The edges should be sharp: they should have neither a radius nor a chamfer.

Slits should be perpendicular to the pipe axis and should have dimensions as follows: (refer to Figure 3)  $i=0.08D$  , and  $2\text{ mm} \leq i \leq 4\text{ mm}$  ,  $k > 2i$ .

7.7.4 A single pressure tapping may be provided and would be suitable for most tests. There should be at least four such pressure tapping holes, equally spaced in one plane around the pipe circumference (see Figure 2, Figure 3 and Figure 3). These would be interconnected by means of tee-shaped connectors to form an annular and to give a true mean static pressure at

the pipe cross-section. Other methods such as ring or balance chamber may also be used.

7.7.5 The upstream and downstream pipes should be round and of smooth bore to minimize pressure loss in the pipe. The minimum dimensions for installing the tappings are shown in Figure 1. The upstream tapping should be positioned a distance of at least  $10 D$ , where  $D$  is the internal pipe diameter, downstream of the entrance to avoid errors being introduced by the entry connection and be positioned at least  $5 D$  upstream of the meter. The downstream tapping should be at least  $10 D$  downstream of the meter to allow pressure to recover following any restrictions within the meter and at least  $5 D$  upstream of the end of the test section.

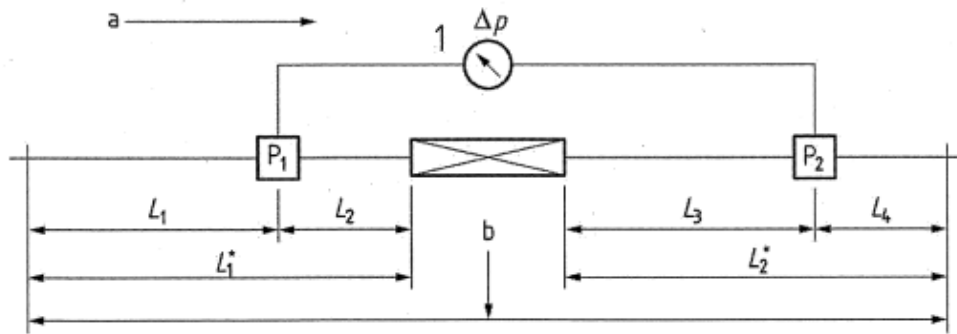

Key

- |        |  |   |
|--------|--|---|
| 1      | differential manometer                             | $L1 \geq 10 D$                                      |
| 2      | water meter ( plus manifold, for concentric meters | $L2 \geq 5 D$                                       |
| P1, P2 | planes of the pressure tappings                    | $L3 \geq 10 D$                                      |
| a      | Flow direction                                     | $L4 \geq 5 D$                                       |
| b      | Measuring section                                  | where $D$ is the internal diameter of the pipe-work |

Figure 1 Pressure loss test: layout of measuring section

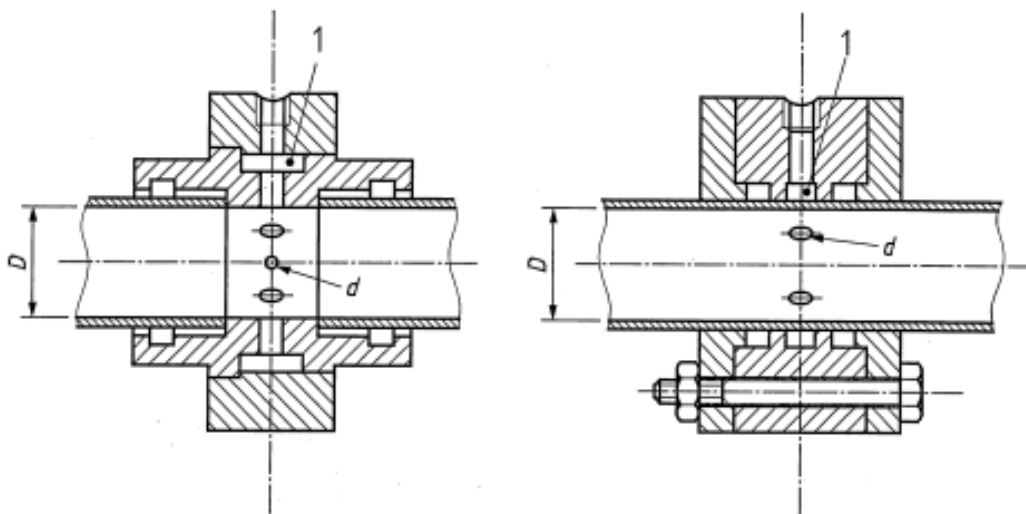

Figure 2 Example of drilled hole type of pressure tapping with ring chamber, suitable for small/medium diameter test sections



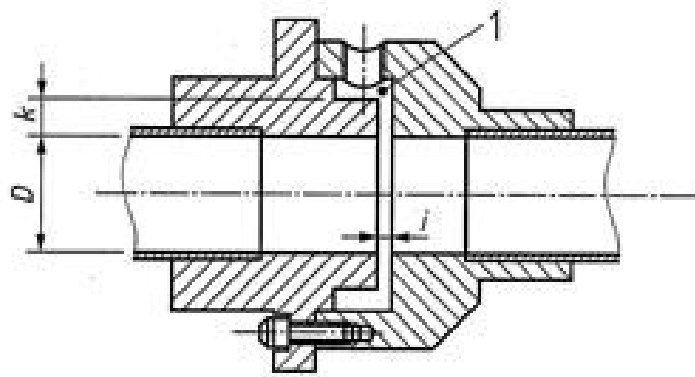
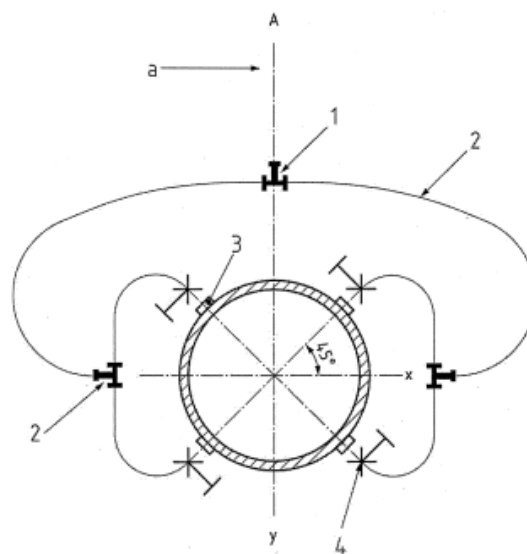
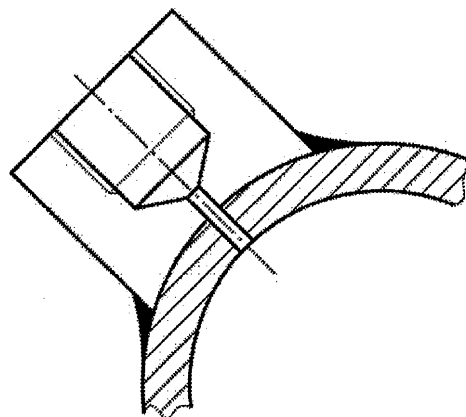

Figure 3 Example of slit type of pressure tapping with ring chamber, suitable for small/medium diameter test sections



B



## Key

- A cross-section through pipe and pressure tapplings
- B detail of pressure tapping and boss
- y vertical axis
- x horizontal axis
- 1 tee
- 2 flexible hose or copper pipe
- 3 pressure tapping (see B)
- 4 isolating cock
- a To manometer

Figure 4 Example of drilled hole type of pressure tapping with connections between tapplings to give mean static pressure, suitable for medium or large diameter test sections.

7.7.6 The meter should be installed in the measuring section in the test facility. Flow is established and all air purged from the test section. Adequate back pressure should be ensured at the downstream pressure tapping at the maximum flow rate  $Q_3$ . As a minimum, a static pressure downstream of the meter under test of 100 kPa (1 bar) is recommended to avoid cavitation or air release. While monitoring the differential pressure, the flow should be varied between  $Q_1$  and  $Q_3$ . The flow rate showing the largest pressure loss,  $Q_t$ , should be noted along with the measured pressure loss and fluid temperature. Normally  $Q_t$  will be found to be equal to  $Q_3$ .

7.7.7 The test section can be rearranged as shown in Figure 5. Calculate the pressure loss,  $\Delta p_t$ , of the water meter.

$$\Delta p_t = \Delta p_{m+p} - \Delta p_p$$

where:

$\Delta p_{m+p}$  is the measured pressure loss at  $Q_t$  with the meter in place;

$\Delta p_p$  is the pressure loss measured without the meter at  $Q_t$ .

If the measured flow rate either during the test or during the determination of the pipe pressure loss is not equal to the selected test flow rate, the measured pressure loss can be corrected to that expected at  $Q_t$  by reference to the square law formula as follows:

$$\Delta p_{Q_t} = \frac{Q_t^2}{Q_{meas}^2} \Delta p_{Q_{meas}}$$

where:

$\Delta p_{Q_t}$  is the calculated pressure loss at  $Q_t$ ;

$Q_{meas}$  is the flow rate when measures the pressure loss

$\Delta p_{Q_{meas}}$  is the measured pressure loss at a flow rate  $Q_{meas}$ .

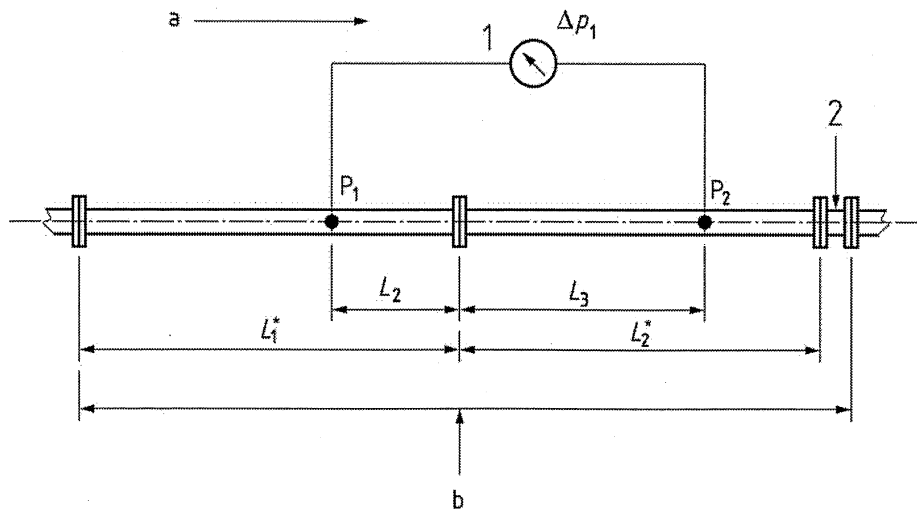

(a) Pipe pressure loss

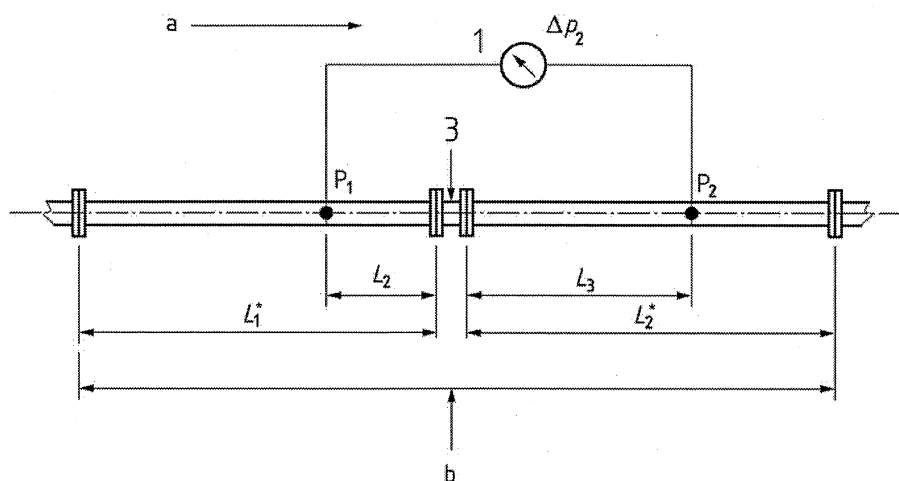

b) (Pipe and water meter) pressure loss

Figure 5 Pressure loss test

Key

- 1 differential manometer
- 2 water meter in downstream position (or temporary pipe)
- 3 water meter

$P_1, P_2$  planes of the pressure tappings

$\Delta p_1$  pressure loss of up- and downstream pipe lengths

$$\Delta p_1 = (\Delta p_{L2} + \Delta p_{L3})$$

$\Delta p_2$  pressure loss of up- and downstream pipe lengths and water meter

$$\Delta p_2 = (\Delta p_{L2} + \Delta p_{L3} + \Delta p_{meter})$$

$$\Delta p_2 - \Delta p_1 = (\Delta p_{L2} + \Delta p_{L3} + \Delta p_{meter}) - (\Delta p_{L2} + \Delta p_{L3}) = \Delta p_{meter}$$

<sup>a</sup> Flow direction

<sup>b</sup> Measuring section

7.8 Flow disturbance tests

Except for the following requirements, all water meters must be tested at a flow rate between  $0.9 Q_3$  and  $Q_3$  in the following order:

- (a) Volumetric water meters (ie, those including measuring chambers with movable walls) are exempt from testing.
- (b) For meters where the manufacturer has specified installation length of straight pipe of at least 15 times DN upstream and 5 times DN downstream of the meter, where DN is the nominal diameter, no external flow straighteners are allowed.
- (c) When a minimum straight pipe length of 5 times DN downstream of the meter is specified by the manufacturer, only tests 1, 3 and 5 shall be performed.
- (d) Where meter installations with external flow straighteners are to be used, the manufacturer shall specify the straightener model, its technical characteristics and its position in the installation relative to the the water meter.
- (e) Please refer to Appendix A for the types of straightener.
- (f) Acceptance standard: refer to Table 1.

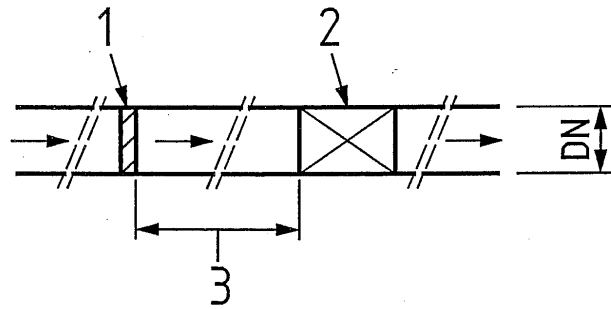

Test 1: without a straightener

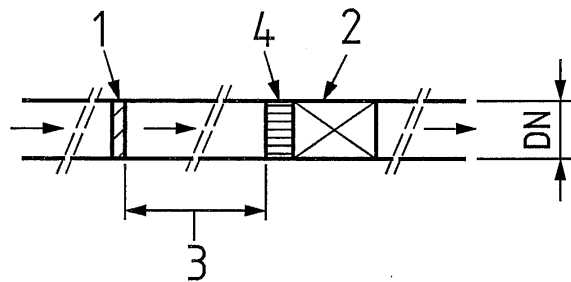

Test 1A: with a straightener

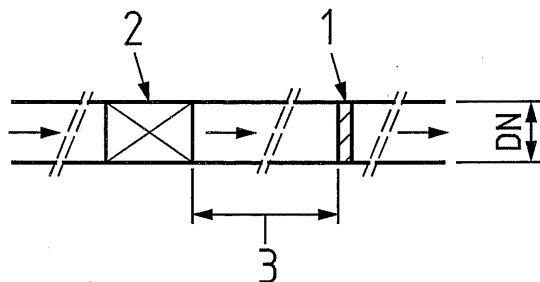

Test 2: without a straightener

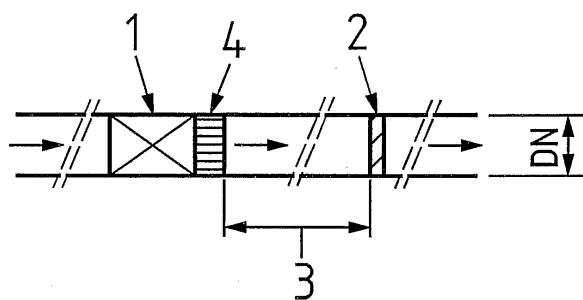

Test 2A: with a straightener

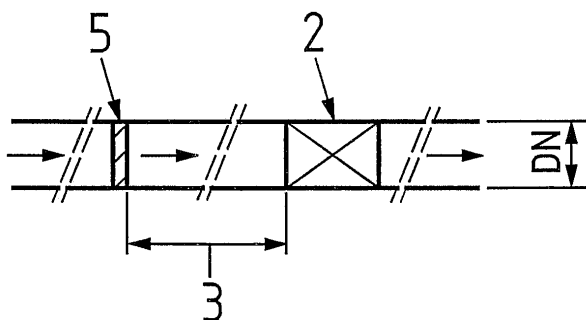

Test 3: without a straightener

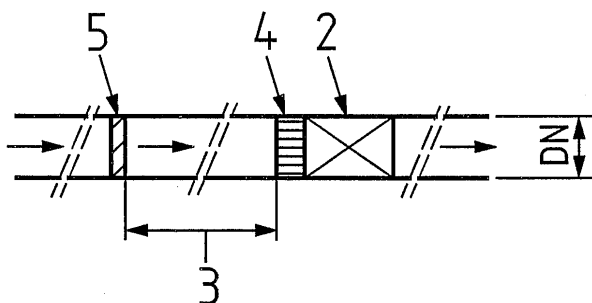

Test 3A: with a straightener

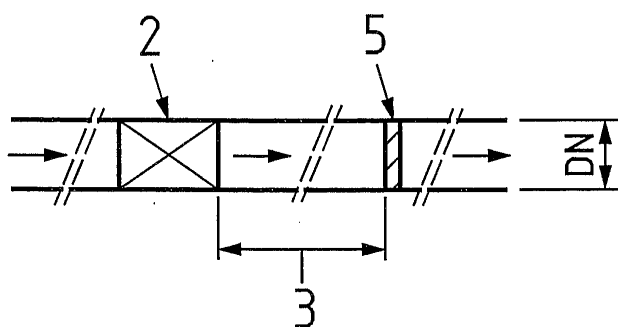

Test 4: without a straightener

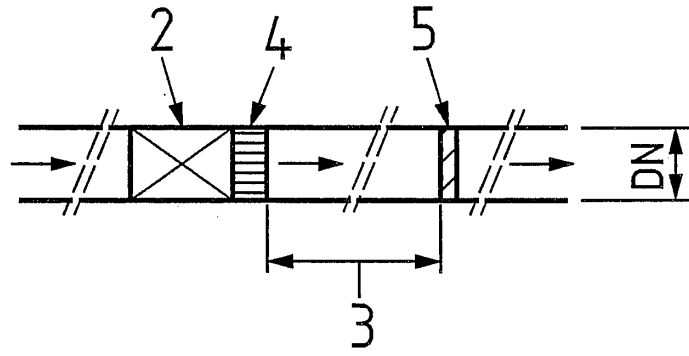

Test 4A: with a straightener

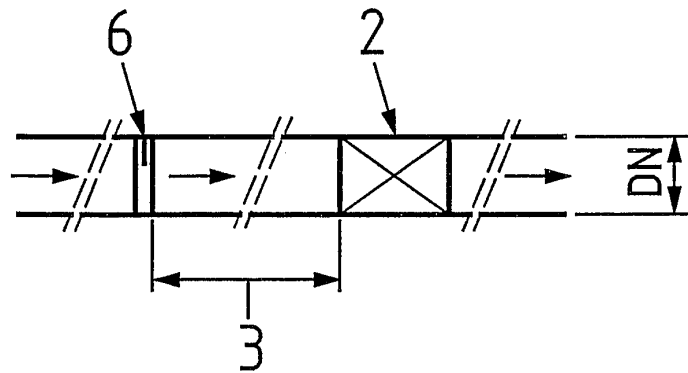

Test 5: without a straightener

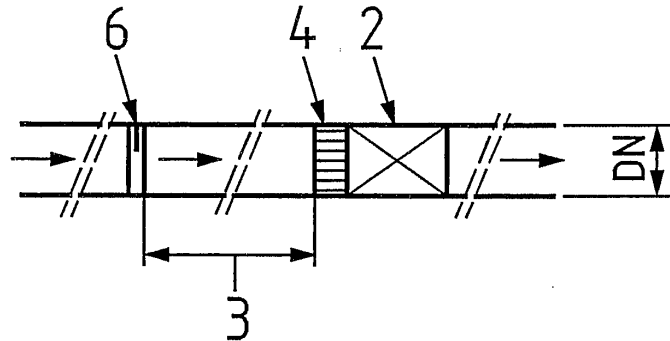

Test 5A: with a straightener

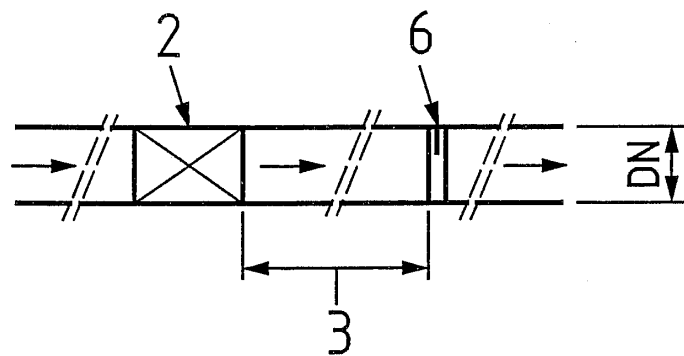

Test 6: without a straightener

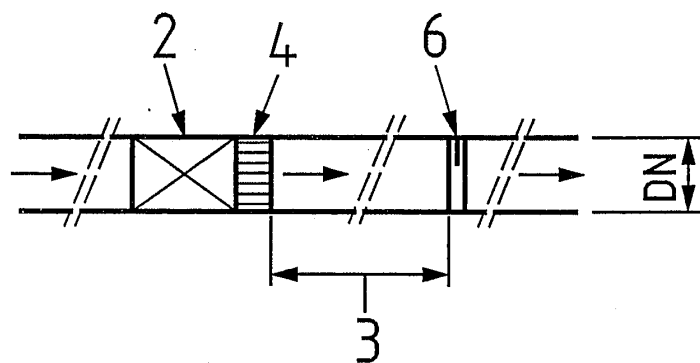

Test 6A: with a straightener

## Key

- 1 type 1 disturber — swirl generator sinistrorsal
- 2 Meter
- 3 straight length
- 4 straightener
- 5 type 2 disturber — swirl generator dextrorsal
- 6 type 3 disturber — velocity profile flow dis

Figure 6 Installation requirements for flow disturbance tests

## 7.9 Durability tests

## 7.9.1 Discontinuous flow test

This test is applied only to meters with  $Q_3 \leq 16 \text{ m}^3/\text{h}$ .

7.9.1.1 The discontinuous flow test consists of subjecting the meter to the specified number of starting and stopping flow rate cycles of short duration. A complete cycle comprises the following four phases: a period from zero to the test flow rate, a period at constant test flow rate, a period from the test flow rate to zero, and a period at zero flow rate. For the convenience of laboratories, the test can be divided up into periods of at least 6 h.

7.9.1.2 The relative variation of the flow values shall not exceed  $\pm 10\%$  outside the opening, closing, and stoppage periods.

The tolerance on the test timing on the specified duration of each phase of the flow cycle shall not exceed  $\pm 10\%$ . The tolerance on the test timing on the total test duration shall not exceed  $\pm 5\%$ .

The total theoretical volume duration of the test with a tolerance of  $\pm 5\%$ .

During the test, the following readings from the test rig shall be recorded at least once every 24 h period, or once for every shorter period if the test is so divided:

- (a) line pressure upstream of the meter(s) under test;
- (b) line pressure downstream of the meter(s) under test;
- (c) line temperature upstream of the meter(s) under test;
- (d) flow rate through the meter(s) under test;
- (e) number of cycles;
- (f) indicated volumes of the meter(s) under test.

7.9.1.3 Following the discontinuous durability test, measure the final errors (of indication) of the meters as specified in Section 7.4.2 and then perform the continuous flow test. The acceptance criteria after discontinuous durability test shall meet the requirements in Table 8.

Table 8 Acceptance criteria after discontinuous durability test

Flow rate	MPE	
	Class 1	Class 2
$Q_1 \leq Q < Q_2$	$\pm 4 \%$	$\pm 6 \%$
$Q_2 \leq Q \leq Q_4$	$\pm 1.5 \%$	$\pm 2.5 \%$

7.9.1.4 Comparing the final errors (of indication) of the meters as specified in Section 7.4.2, the variation in the error curve shall meet the requirements in Table 9. For the purpose of determining these requirements, the mean values of the errors (of indication) at each flow rate shall apply.

Table 9 The variation in the error curve after the discontinuous durability test

Flow rate	Maximum error limit of variation curves	
	Class 1	Class 2
$Q_1 \leq Q < Q_2$	$\pm 2 \%$	$\pm 3 \%$
$Q_2 \leq Q \leq Q_4$	$\pm 1 \%$	$\pm 1.5 \%$

7.9.2 Continuous flow test

7.9.2.1 The test consists of subjecting the meter to constant flow rate of  $Q_3$  or  $Q_4$  for a specified duration. For the convenience of laboratories, the test can be divided up into periods of at least 6 h.

7.9.2.2 The relative variation of the flow rate values during each test shall not exceed  $\pm 10 \%$



(except when starting and stopping). The water meter(s) on test may be used to check the flow rate.

During the test, the following readings from the test rig shall be recorded at least once every 24 h period, or once for every shorter period if the test is so divided:

- (a) water pressure upstream of the meter(s) under test;
- (b) water pressure downstream of the meter(s) under test;
- (c) water temperature upstream of the meter(s) under test;
- (d) flow rate through the meter(s) under test;
- (e) indicated volume of the meter(s) under test.

7.9.2.3 After the continuous durability test(s), measure the errors (of indication) of the meter(s) as specified in Section 7.4.2. Calculate the relative error (of indication) for each flow rate. Acceptance criteria after continuous flow test shall meet the requirements in Table 10.

Table 10 Acceptance criteria after continuous durability test

Flow rate	MPE	
	Class 1	Class 2
$Q_1 \leq Q < Q_2$	± 4 %	± 6 %
$Q_2 \leq Q \leq Q_4$	± 1.5 %	± 2.5 %

7.9.2.4 Compare the error (of indication) obtained of the following with the error (of indication) obtained in Section 7.9.2.3

- (a) When  $Q_3 \leq 16 \text{ m}^3/\text{h}$ , compare the error (of indication) obtained in Section 7.9.1.3;
- (b) When  $Q_3 > 16 \text{ m}^3/\text{h}$ , compare the error (of indication) obtained in Section 7.4.2.

Table 11 The variation in the error curve after the continuous durability test

Flow rate	Maximum error limit of variation curves	
	Class 1	Class 2
$Q_1 \leq Q < Q_2$	±2 %	±3 %
$Q_2 \leq Q \leq Q_4$	±1 %	±1.5 %

7.9.3 others

The same meters shall be submitted to the discontinuous and continuous tests and the test order shall not be changed. As specified in Table 12.

Table 12 Summary of discontinuous, continuous tests

Permanent flow rate	$Q_3 \text{ m}^3/\text{h} \leq 16$		$Q_3 \text{ m}^3/\text{h} > 16$	
	Test flowrate	$Q_4$	$Q_3$	$Q_4$
Test of type	discontinuous	continuous	continuous	continuous
Number of interrupts	100,000	—	—	—
Time of pauses	15 s	—	—	—
Time of test at test flow rate	15 s	100 h	800 h	200 h

Duration of start-up and rundown	0.15[Q <sub>3</sub> ] <sup>a</sup> s with a minimum of 1 s	—	—	—
<sup>a</sup> [Q <sub>3</sub> ] is the number equal to the value of Q <sub>3</sub> expressed in m <sup>3</sup> /h.				

7.10 Magnetic field testing

7.10.1 All water meters where the mechanical components may be influenced by a static magnetic field (e.g. equipped with a magnetic coupling in the drive to the readout or with a magnet-driven pulse output) and all meters with electronic components shall be tested to show that they are able to withstand the influence of a static magnetic field. Equipment under test is measured at flow rate, Q<sub>1</sub> and Q<sub>2</sub>. The relative errors (of indication) shall not exceed the maximum permissible errors given in Table 1 in section 3.2.

7.10.2 The magnetic field source for the test may be a permanent magnet or electric magnet and the intensity of the magnetic field shall be 1500 Gauss at the shell of meter. In a free space, the range of the values shall be within maximum permissible errors listed in Table 13.

Table 13 Quantified Intensity Distance Relation

Distance from Maximum Intensity Point (mm)	Ratio to 1500 Gauss Intensity (%)
0	≥100
10	≥58.1
20	≥36.0
30	≥23.7
40	≥16.4
50	≥11.8
60	≥8.7
70	≥6.7

7.10.3 The test points of a water meter tested are all located on the meter shell. Centered on the sensing magnet inside the meter as the reference point, test points are distributed in a radial pattern as shown in Fig.7 and Fig.8. There are two adjacent test points and a central reference point. Points to be measured are at 45-degree angle. There are 6 test points in total.

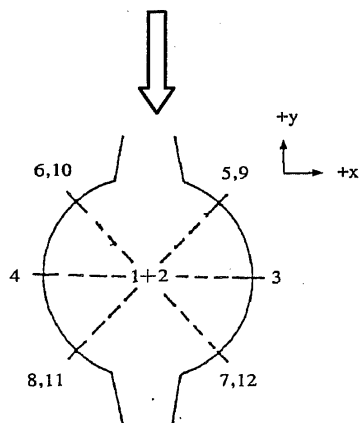

Fig 7 Top View of Tested Meter

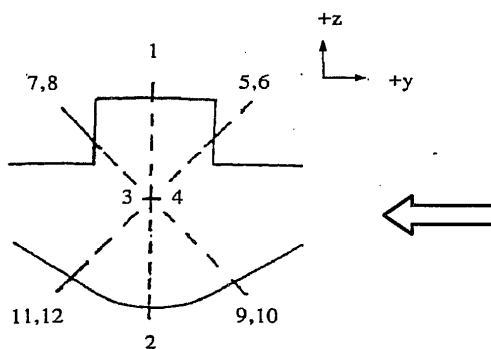

Fig 8 Side View of Tested Meter

7.10.4 Antimagnetic function tests shall be performed according to above method and conditions and one for each symmetric test point. If there is any test point at which the indication errors of the tested meter exceed the maximum permissible errors for the flow-rate, the meter is failed in the test.

8. Performance test of water meters equipped with electronic devices

This section applies to water meters that based on electrical or electronic principles or mechanical principles incorporating electronic devices.

## 8.1 Tests involving the electronic part of a water meter or its devices

- a. Dry heat (Section 8.4)
- b. Cold (Section 8.5)
- c. Damp heat, cyclic (Section 8.6)
- d. Mains voltage variation
- e. Powered by direct AC or by AC/DC converters (Section 8.7)
- f. Water meters powered by external DC voltage or by primary DC batteries (Section 8.8)
- g. Interruption in battery supply (Section 8.9)
- h. AC mains voltage dips, short interruptions and voltage variations (Section 8.10)
- i. Bursts on signal lines (Section 8.11)
- j. Bursts (transients) on AC and DC mains (Section 8.12)
- k. Electrostatic discharge (Section 8.13)
- l. Radiated electromagnetic fields (Section 8.14)
- m. Conducted electromagnetic fields (Section 8.15)
- n. Surges on signal, data and control lines (Section 8.16)
- o. Surges on AC and DC mains power lines (Section 8.17)
- p. Static magnetic field (Section 8.18)
- q. Absence of flow test (Section 8.19)

## 8.2 Reference conditions

## 8.2.1 Flow rate

$$0.7 \times (Q_2 + Q_3) \pm 0.03 \times (Q_2 + Q_3)$$

## 8.2.2 Water temperature

$$25 \text{ °C} \pm 10 \text{ °C}$$

## 8.2.3 Water pressure

$$0.03 \text{ MPa (0.3 bar) to } 1 \text{ MPa (10 bar)}$$

## 8.2.4 Ambient temperature range

$$15 \text{ °C to } 35 \text{ °C}$$

## 8.2.5 Ambient relative humidity range

$$45 \% \text{ to } 95 \%$$

## 8.2.6 Ambient atmospheric pressure range

$$86 \text{ kPa to } 106 \text{ kPa (0.86 bar to } 1.06 \text{ bar)}$$

## 8.2.7 Power supply voltage (mains AC)

$$\text{Nominal voltage, } U_{\text{nom}} \pm 5 \%$$

## 8.2.8 Power supply frequency

$$\text{Nominal frequency, } f_{\text{nom}} \pm 2 \%$$

## 8.2.9 Power supply voltage (battery)

$$\text{A voltage } V \text{ in the range } U_{\text{bmin}} \leq V \leq U_{\text{bmax}}$$

## 8.2.10 Test volumes for measuring error (of indication) of a water meter

For items not specified, the test volume for measuring the error of indication of the meter

shall correspond to that delivered in 1 min at the overload flow rate  $Q_4$ .

### 8.3 Environmental classification

#### 8.3.1 Climatic environmental classification

8.3.1.1 Class B for fixed meters installed in a building.

8.3.1.2 Class O for fixed meters installed outdoors.

#### 8.3.2 Electromagnetic environments

8.3.2.1 E1 – residential, commercial and light industrial

8.3.2.2 E2 – industrial.

### 8.4 Dry heat

#### 8.4.1 Preparation

Follow the test arrangements specified in IEC 60068-2-2.

Guidance on testing arrangements is given in IEC 60068-3-1 and IEC 60068-1

#### 8.4.2 Test procedure

8.4.2.1 Before conditioning the water meter under test, place the water meter at the reference air temperature of  $25\text{ °C} \pm 10\text{ °C}$  and calculate the relative error (of indication) for each test condition in accordance with Section 8.2.

8.4.2.2 Measure the error (of indication) of the water meter under test at an air temperature of  $55\text{ °C} \pm 2\text{ °C}$ , after the water meter under test has been stabilized at this temperature for a period of 2 h

8.4.2.3 Measure the error (of indication) of the water meter under test at the reference air temperature of  $25\text{ °C} \pm 5\text{ °C}$ , after recovery of the water meter under test.

8.4.2.4 The water flow direction of the water meter under test is specified in Section 7.4.3.

#### 8.4.3 Acceptance criteria

8.4.3.1 All the functions of the water meter under test shall operate as designed;

8.4.3.2 The relative error (of indication) of the water meter under test, at the test conditions, shall not exceed the maximum permissible error of the upper flow rate zone in Table 1 in Section 3.2.

### 8.5 Cold

#### 8.5.1 Preparation

Follow the testing arrangements specified in IEC 60068-2-1.

Guidance on testing arrangements is given in IEC 60068-3-1 and IEC 60068-1.

#### 8.5.2 Test procedure

8.5.2.1 Do not pre-condition the water meter under test. Measure the error (of indication) of the water meter under test in accordance with Section 8.2 at the reference flow rate and at the reference air temperature of  $25\text{ °C} \pm 10\text{ °C}$ .

8.5.2.2 Stabilize the air temperature at  $10\text{ °C} \pm 3\text{ °C}$  for a period of 2 h.

8.5.2.3 Measure the error (of indication) of the water meter under test at the reference flow rate at an air temperature of  $10\text{ °C} \pm 3\text{ °C}$ .

8.5.2.4 After recovery of the water meter under test, measure the error (of indication) of the water meter under test at the reference flow rate and at the reference air temperature.

8.5.2.5 The water flow direction of the water meter under test is specified in Section 7.4.3.

#### 8.5.3 Acceptance criteria

8.5.3.1 All the functions of the water meter under test shall operate as designed; and

8.5.3.2 The relative error (of indication) of the water meter under test, at the test conditions, shall not exceed the maximum permissible error of the upper flow rate zone in Table 1 in Section 3.2.

### 8.6 Damp heat, cyclic

#### 8.6.1 Preparation

Follow the testing arrangements specified in IEC 60068-2-30.

Guidance on testing arrangements is given in IEC 60068-3-4.

Two 24-hour cycles, each cycle includes Sections 8.6.2.1 to Sections 8.6.2.5.

#### 8.6.2 Test procedure

8.6.2.1 Pre-condition the water meter under test. Expose the water meter under test at temperature of  $25\text{ °C} \pm 3\text{ °C}$  and maintain the relative humidity above 95 %.

8.6.2.2 Temperature rise to  $55\text{ °C} \pm 2\text{ °C}$  over 3 h.

8.6.2.3 Temperature maintained at upper value and maintain the relative humidity above 95 % until 12 h from the start of the cycle.

8.6.2.4 Temperature taken down to the lower value within 3 h to 6 h, the rate of fall during the first 1 h 30 min being such that the temperature of  $25\text{ °C} \pm 3\text{ °C}$  would be reached in 3 h.

8.6.2.5 Temperature maintained at  $25\text{ °C} \pm 3\text{ °C}$  and the relative humidity of  $93\% \pm 3\%$  until the 24 h cycle is completed.

8.6.2.6 Allow the water meter under test to recover. After recovery, all parts of the water meter under test are within  $3\text{ °C}$  of their final temperature. Measure the error (of indication) of the water meter under test at the reference flow rate.

8.6.2.7 The water flow direction of the water meter under test is specified in Section 7.4.3.

#### 8.6.3 Acceptance criteria

8.6.3.1 All the functions of the water meter under test shall operate as designed.

8.6.3.2 Either the difference between any indication before the test and the indication after the test shall not exceed one-half of the maximum permissible error in the upper flow rate zone in Table 1 in Section 3.2 or the water meter under test shall detect and act upon a significant fault.

### 8.7 Power supply variation- Water meters powered by direct AC or by AC/DC converters

#### 8.7.1 Preparation

Follow the testing arrangements specified in IEC 61000-4-11, IEC 61000-2-1, IEC 61000-2-2, IEC 61000-4-1, and IEC 60654-2.

### 8.7.2 Test procedure

8.7.2.1 Measure the error (of indication) of the water meter under test during the application of the upper mains voltage limit,  $U_{nom} + 10\%$

8.7.2.2 Measure the error (of indication) of the water meter under test during the application of the upper mains frequency limit,  $f_{nom} + 2\%$ .

8.7.2.3 Measure the error (of indication) of the water meter under test during the application of the lower mains voltage limit,  $U_{nom} - 15\%$

8.7.2.4 Measure the error (of indication) of the water meter under test during the application of the lower mains frequency limit,  $f_{nom} - 2\%$ .

### 8.7.3 Acceptance criteria

8.7.3.1 All the functions of the water meter under test shall operate as designed;

8.7.3.2 The relative error of indication of the water meter under test, at the test conditions, shall not exceed the maximum permissible error of the upper flow rate zone in Table 1 in Section 3.2.

## 8.8 Power supply variation- Water meters powered by external DC voltage or by primary DC batteries

### 8.8.1 Test procedure

8.8.1.1 Measure the error (of indication) of the water meter under test, during the application of the maximum operating voltage of the battery, as specified by the water meter supplier, for a battery or the DC voltage at which the water meter under test has been manufactured to automatically detect high-level conditions for an external DC supply.

8.8.1.2 Measure the error (of indication) of the water meter under test, during the application of the minimum operating voltage of the battery, as specified by the water meter supplier, for a battery or the DC voltage at which the water meter under test has been manufactured to automatically detect low-level conditions for an external DC supply.

### 8.8.2 Acceptance criteria

8.8.2.1 All the functions of the water meter under test shall operate as designed;

8.8.2.2 The relative error (of indication) of the water meter under test at the test conditions shall not exceed the maximum permissible error of the upper flow rate zone in Table 1 in Section 3.2.

## 8.9 Power supply variation - Interruption in battery supply

This section applies only to water meters with replaceable batteries.

### 8.9.1 Test procedure

8.9.1.1 Remove the battery.

8.9.1.2 A period of 1 h after remove the battery and then reconnect it.

8.9.1.3 Interrogate the functions of the meter.

### 8.9.2 Acceptance criteria

8.9.2.1 All the functions of the water meter under test shall operate as designed;

8.9.2.2 The value of the totalization or the stored values shall remain unchanged.

## 8.10 AC mains voltage dips, short interruptions and voltage variations

The test in this section is only applicable to the water meter with external AC power supply.

### 8.10.1 Preparation

Follow the testing arrangements specified in IEC 61000-4-11, IEC 61000-6-1, and IEC 61000-6-2.

### 8.10.2 Test procedure

8.10.2.1 Measure the error (of indication) of the water meter under test in accordance with Section 8.2 before applying power reduction test.

8.10.2.2 Measure the error (of indication) of the water meter under test in accordance with Section 8.2 during the application of at least 10 voltage interruptions and 10 voltage reductions with an interval of at least 10 s.

8.10.2.3 A test generator is used which is suitable to reduce the amplitude of the AC mains voltage for a defined period of time. The performance of the test generator shall be verified before connecting the water meter under test.

8.10.2.4 Voltage interruptions and voltage reductions are applied throughout the period required to measure the error (of indication) of the water meter under test. Voltage interruptions: the supply voltage is reduced from its nominal value,  $U_{nom}$ , to zero voltage, for the duration of 300 cycles (60 Hz). Voltage interruptions are applied in groups of 10.

8.10.2.5 Voltage reductions: the supply voltage is reduced from nominal voltage to zero voltage, for the duration of 0.5 cycles (60 Hz); reduced from nominal voltage to zero voltage, for the duration of 1 cycle (60 Hz); and reduced from nominal voltage to 70 % voltage, for the duration of 30 cycles (60 Hz). Voltage reductions are applied in groups of 10.

8.10.2.6 The water flow direction of the water meter under test is specified in Section 7.4.3.

### 8.10.3 Acceptance criteria

8.10.3.1 All the functions of the water meter under test shall operate as designed;

8.10.3.2 The difference between the relative error (of indication) obtained during the application of the short time power reductions and that obtained at the same flow rate before the test, under reference conditions, shall not exceed one-half of the maximum permissible error in the upper flow rate zone in Table 1 in Section 3.2 or the water meter under test shall detect and act upon a significant fault.

## 8.11 Bursts on signal lines

### 8.11.1 Preparation

Follow the testing arrangements specified in IEC 61000-4-4 and IEC 61000-4-1.

To verify that a water meter containing electronics and provided with input/output (I/O) and communication ports (including its external cables).

### 8.11.2 Test procedure



8.11.2.1 Measure the error (of indication) of the water meter under test in accordance with Section 8.2 before applying the electrical bursts.

8.11.2.2 Measure the error (of indication) of the water meter under test in accordance with Section 8.2 during the application of bursts of transient voltage spikes, of double exponential waveform.

8.11.2.3 A burst generator shall be used with the performance characteristics as specified in the cited standard.

8.11.2.4 Each spike shall have an amplitude (positive or negative) of 0.5 kV for environmental class E1 instruments or 1 kV for environmental class E2 instruments, phased randomly, with a rise time of 5 ns and a half amplitude duration of 50 ns.

8.11.2.5 The burst length shall be 15 ms and the burst repetition rate shall be 5 kHz.

8.11.2.6 The injection network on the mains shall contain blocking filters to prevent the burst energy from being dissipated in the mains.

8.11.2.7 For the coupling of the bursts into the I/O and communication lines, a capacitive coupling clamp as defined in the standard shall be used.

8.11.2.8 The duration of the test shall not be less than 1 min for each amplitude and polarity.

8.11.2.9 The water flow direction of the water meter under test is specified in Section 7.4.3.

#### 8.11.3 Acceptance criteria

8.11.3.1 After the application of the disturbance, all the functions of the water meter under test shall operate as designed.

8.11.3.2 The difference between the relative error of indication, obtained during the application of the bursts and that obtained at the same flow rate before the test, under reference conditions, shall not exceed one-half of the maximum permissible error in the upper flow rate zone in Table 1 in Section 3.2 or the water meter under test shall detect and act upon a significant fault.

#### 8.12 Bursts (transients) on AC and DC mains

##### 8.12.1 Preparation

Follow the testing arrangements specified in IEC 61000-4-4 and IEC 61000-4-1.

##### 8.12.2 Test procedure

8.12.2.1 Measure the error (of indication) of the water meter under test in accordance with Section 8.2 before applying the electrical bursts.

8.12.2.2 Measure the error (of indication) of the water meter under test in accordance with Section 8.2 during the application of bursts of transient voltage spikes, of double exponential waveform.

8.12.2.3 A burst generator shall be used with the performance characteristics as specified in the cited standard.

8.12.2.4 Each spike shall have an amplitude (positive or negative) of 1 kV for environmental class E1 instruments or 2 kV for environmental class E2 instruments, phased

randomly, with a rise time of 5 ns and a half amplitude duration of 50 ns.

8.12.2.5 The burst length shall be 15 ms and the burst repetition rate shall be 5 kHz.

8.12.2.6 The water flow direction of the water meter under test is specified in Section 7.4.3.

### 8.12.3 Acceptance criteria

8.12.3.1 After the application of the disturbance, all the functions of the water meter under test shall operate as designed.

8.12.3.2 The difference between the relative error of indication, obtained during the application of the bursts and that obtained at the same flow rate before the test, under reference conditions, shall not exceed one-half of the maximum permissible error in the upper flow rate zone in Table 1 in Section 3.2 or the water meter under test shall detect and act upon a significant fault.

## 8.13 Electrostatic discharge

### 8.13.1 Preparation

Follow the testing arrangements specified in IEC 61000-4-2.

### 8.13.2 Test procedure

8.13.2.1 Measure the error (of indication) of the water meter under test in accordance with Section 8.2 before applying the electrostatic discharges.

8.13.2.2 Charge a 150 pF capacitor by means of a suitable DC voltage source, then discharge the capacitor through the water meter under test by connecting one terminal of the supporting chassis to earth and the other via a 330  $\Omega$  resistor to surfaces of the water meter under test which are normally accessible to the operator. If there has a coating of the water meter under test, the coating must be scratched off at the test point before test.

8.13.2.3 For each contact discharge, a voltage of 6 kV shall be applied; for each air discharge, a voltage of 8 kV shall be applied;

8.13.2.4 At each test location, at least 10 direct discharges shall be applied at intervals of at least 10 s between discharges, during the same measurement or simulated measurement; for indirect discharges, a total of 10 discharges shall be applied on the horizontal coupling plane and a total of 10 discharges for each of the various positions of the vertical coupling plane.

8.13.2.5 Measure the error (of indication) of the water meter under test during the application of electrostatic discharges.

8.13.2.6 For water meter under test not equipped with an earth terminal, the water meter under test shall be fully discharged between discharges.

8.13.2.7 Contact discharge is the preferred test method. Air discharges shall be used where contact discharge cannot be applied.

8.13.2.8 The water flow direction of the water meter under test is specified in Section 7.4.3.

### 8.13.3 Acceptance criteria

8.13.3.1 After the application of the disturbance, all the functions of the water meter under test shall operate as designed.

8.13.3.2 The difference between the relative error (of indication), obtained during the application of the electrostatic discharges and that obtained before the test, at the same flow rate, under reference conditions, shall not exceed one-half of the maximum permissible error in the upper flow rate zone in Table 1 in Section 3.2 or the water meter under test shall detect and act upon a significant fault.

8.14 Radiated electromagnetic fields

8.14.1 Preparation

Follow the testing arrangements specified in IEC 61000-4-3.

8.14.2 Test procedure

8.14.2.1 Measure the intrinsic error (of indication) of the water meter under test in accordance with Section 8.2 before applying the electromagnetic field.

8.14.2.2 The water meter under test, and its external cables of at least 1.2 m length, shall be subjected to radiated electromagnetic fields at field strengths of either 3 V/m for environmental class E1 instruments or 10 V/m for environmental class E2 instruments. The test is performed as several partial scans with a vertical antenna and several partial scans with a horizontal antenna.

Recommended start and stop frequencies for each scan are listed in Table 14. The frequency range for this radiated electromagnetic fields test is 26 MHz to 2 GHz, or 80 MHz to 2 GHz when the test for frequencies in the lower range in Table 15 in Section 8.15 is applicable.

Table 14 Start and stop carrier frequencies (Radiated electromagnetic fields)

MHz	MHz	MHz
26	160	600
40	180	700
60	200	800
80	250	934
100	350	1000
120	400	1400
144	435	2000
150	500	
Note: Breakpoints are approximate.		

8.14.2.3 During each scan, the frequency shall be changed in steps of 1 % of actual frequency, until the next frequency in Table 4 is reached. The dwell time at each 1 % step shall be identical. However, the dwell time shall be equal for all carrier frequencies in the scan and shall be sufficient for the water meter under test to be exercised and able to respond at each frequency. The error (of indication) measurements shall be carried out

with all of the scans listed in Table 14.

8.14.2.4 Change the polarization of the antenna.

8.14.2.5 Repeat steps in Section 8.14.2.3 until all the carrier frequencies listed in Table 14 are completed.

8.14.2.6 The water flow direction of the water meter under test is specified in Section 7.4.3.

#### 8.14.3 Acceptance criteria

8.14.3.1 After the application of the disturbance, all the functions of the water meter under test shall operate as designed.

8.14.3.2 The difference between the relative error (of indication) measured during the application of each carrier frequency band and that obtained at the same flow rate before the test, under reference conditions, shall not exceed one-half of the maximum permissible error in the upper flow rate zone in Table 1 in Section 3.2 or the water meter under test shall detect and act upon a significant fault.

#### 8.15 Conducted electromagnetic fields

##### 8.15.1 Preparation

Follow the testing arrangements specified in IEC 61000-4-6. However, the test procedure specified in Section 8.15.2 is a modified procedure from IEC,

Where there are discrepancies between this specification and IEC 61000-4-6, this specification shall govern.

##### 8.15.2 Test procedure

8.15.2.1 Measure the intrinsic error (of indication) of the water meter under test in accordance with Section 8.2 at reference conditions before applying the electromagnetic field.

8.15.2.2 The water meter under test shall be subjected to conducted electromagnetic fields at RF amplitude of either 3V for environmental class E1 instruments, or 10 V for environmental class E2 instruments. The frequency range for this conducted electromagnetic fields test is 0.15 MHz to 80 MHz. Recommended start and stop frequencies for each scan are listed in Table 15.

8.15.2.3 During each scan, the frequency shall be changed in steps of 1 % of actual frequency. The dwell time at each 1 % step shall be identical. However, the dwell time shall be equal for all carrier frequencies in the scan and shall be sufficient for the water meter under test to be exercised and able to respond at each frequency. The error (of indication) measurements shall be carried out with all of the scans listed in Table 5.

8.15.2.4 The water flow direction of the water meter under test is specified in Section 7.4.3.

8.15.2.5 Repeat steps in 8.15.2.3 until all the carrier frequencies listed in Table 15 are completed.

Table 15 Start and stop carrier frequencies (Conducted electromagnetic fields)

MHz	MHz	MHz
0.15	2.2	30
0.30	3.9	50
0.57	7.5	80
1.1	14	
Note: Break points are approximate.		

### 8.15.3 Acceptance criteria

8.15.3.1 After the application of the disturbance, all the functions of the water meter under test shall operate as designed.

8.15.3.2 The difference between the relative error (of indication) measured during the application of each carrier frequency band and that obtained at the same flow rate before the test, under reference conditions, shall not exceed one-half of the maximum permissible error in the upper flow rate zone in Table 1 in Section 3.2 or the water meter under test shall detect and act upon a significant fault.

### 8.16 Surges on signal, data and control lines

#### 8.16.1 Preparation

Follow the testing arrangements specified in IEC 61000-4-5.

#### 8.16.2 Test procedure

8.16.2.1 Measure the error (of indication) of the water meter under test in accordance with Section 8.2 before applying the surges.

8.16.2.2 The surges have to be applied line to line and line(s) to earth. When testing line to earth, the test voltage shall be applied successively between each of the lines and earth, if there is no other specification.

8.16.2.3 Measure the error (of indication) of the water meter under test after the application of surge transient voltages.

8.16.2.4 This test is only applicable for environmental class E2, for which the surge transient voltage on line to line is 1 kV, and on line to earth is 2 kV.

8.16.2.5 The water flow direction of the water meter under test is specified in Section 7.4.3.

#### 8.16.3 Acceptance criteria

8.16.3.1 After the application of the disturbance, all the functions of the water meter under test shall operate as designed.

8.16.3.2 The difference between the relative error of indication obtained after the application of the surge transient voltages and that obtained before the test shall not exceed one-half of the MPE of the “upper zone“ in Table 1 in Section 3.2 or the water meter under test shall detect and act upon a significant fault.

### 8.17 Surges on AC and DC mains power lines

#### 8.17.1 Preparation

Follow the testing arrangements specified in IEC 61000-4-5.

#### 8.17.2 Test procedure

8.17.2.1 Measure the error (of indication) of the water meter under test in accordance with Section 8.2 before applying the surge transient voltages.

8.17.2.2 If not otherwise specified, the surges have to be applied synchronized to the voltage phase at the zero-crossing and the peak value of the AC voltage wave (positive and negative).

8.17.2.3 The surges have to be applied line to line and line(s) to earth. When testing line to earth the test voltage shall be applied successively between each of the lines and earth, if there is no other specification.

8.17.2.4 Measure the error (of indication) of the water meter under test after the application of surge transient voltages.

8.17.2.5 This test is only applicable for environmental class E2, for which the surge transient voltage on line to line is 1 kV, and on line to earth is 2 kV.

8.17.2.6 On AC mains supply lines at least three positive and three negative surges shall be applied synchronously with AC supply voltage in angles 0°, 90°, 180° and 270°.

8.17.2.7 On DC power lines, at least three positive and three negative surges shall be applied;

8.17.2.8 The water flow direction of the water meter under test is specified in Section 7.4.3.

#### 8.17.3 Acceptance criteria

8.17.3.1 After the application of the disturbance, all the functions of the water meter under test shall operate as designed.

8.17.3.2 The difference between the relative error of indication obtained after the application of the surge transient voltages and that obtained before the test shall not exceed one-half of the MPE of the “upper zone” in Table 1 in Section 3.2 or the water meter under test shall detect and act upon a significant fault.

#### 8.18 Static magnetic field

Test procedures, requirements and acceptance criteria are the same as in Section 7.10.

#### 8.19 Absence of flow test

##### 8.19.1 Test procedure

8.19.1.1 Fill the meter with water, purging out all air.

8.19.1.2 Ensure there is no flow through the measurement transducer. Observe the meter index for 15 min.

8.19.1.3 Fully discharge the water from the meter. Observe the meter index for 15 min.

##### 8.19.2 Acceptance criteria

8.19.2.1 The water meter totalization shall not change by more than the value of the verification scale interval during each test interval.

#### 9. Implementation date

This specification will be implemented from July 1, 2023 for mechanical water meters, and for water meters with electronic devices from January 1, 2026; the correction period ends on December 31, 2027.

## Appendix A Flow disturbers

### A.1 General

Figures A.1 to A.12 show flow disturber types to be used in tests as specified in Section 7.8.

All dimensions shown in the drawings are in millimetres, unless otherwise stated.

Machined dimensions shall have a tolerance of  $\pm 0.25$  mm unless otherwise stated.

### A2. Threaded type disturbance generators

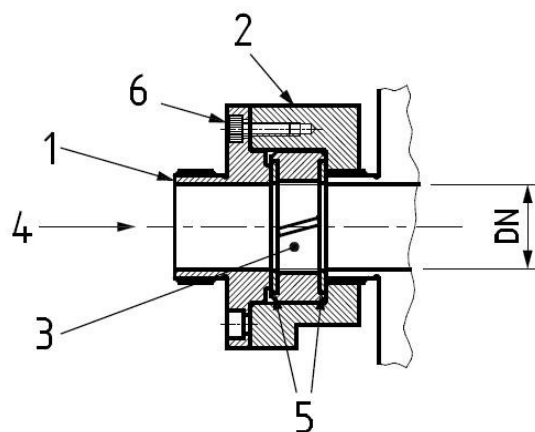

Item	Description	Quantity	Material
1	cover	1	stainless steel
2	body	1	stainless steel
3	swirl generator	1	stainless steel
4	flow	—	—
5	gasket	2	fibre
6	hexagon socket head cap screw	4	stainless steel

type 1 disturber – Sinistrorsal swirl generator;

type 2 – Dextrorsal swirl generator

Figure A.1 Threaded type disturbance generator – Arrangement of swirl generator units

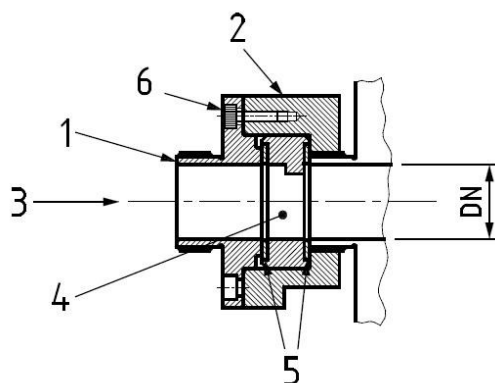



Item	Description	Quantity	Material
1	cover	1	stainless steel
2	body	1	stainless steel
3	flow	—	—
4	flow disturber	1	stainless steel
5	gasket	2	fibre
6	hexagon socket head cap screw	4	stainless steel

type 3 disturber – Velocity profile flow disturber

Figure A.2 Threaded type disturbance generator – Arrangement of velocity profile disturbance units

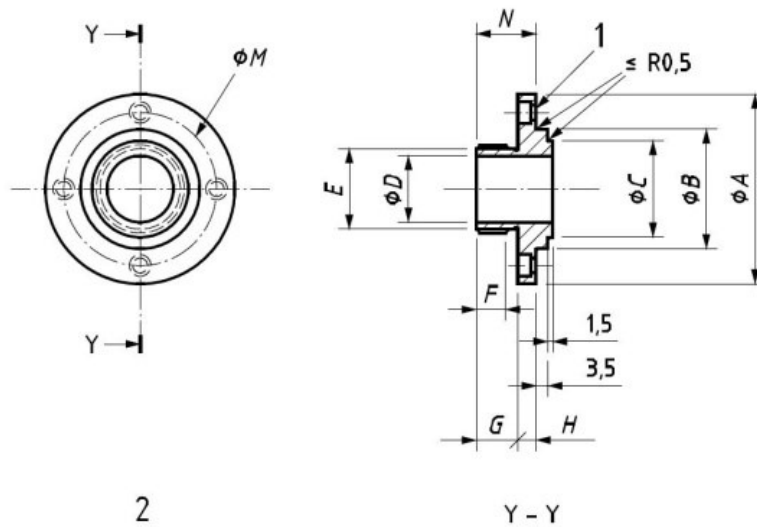

Key

- 1 4 holes  $\phi J$ , bore  $\phi K \times L$  Machined surface roughness  $3.2 \mu\text{m}$  all over

Figure A.3 Cover for a threaded type disturbance generator, with dimensions as set out in Table A.1

Table A.1 Dimensions for the cover (item 1) for a threaded type disturbance generator

unit : mm

threaded type disturbance generator – item 1 : cover													
DN	A	B(e9 <sup>a</sup> )	C	D	E <sup>(b)</sup>	F	G	H	J	K	L	M	N
15	52	29.960 29.908	23	15	G3/4" B	10	12.5	5.5	4.5	7.5	4	40	23
20	58	35.950 35.888	29	20	G1" B	10	12.5	5.5	4.5	7.5	4	46	23
25	63	41.950 41.888	36	25	G1 1/4" B	12	14.5	6.5	5.5	9.0	5	52	26
32	76	51.940 51.866	44	32	G1 1/2" B	12	16.5	6.5	5.5	9.0	5	64	28
40	82	59.940 59.866	50	40	G2" B	13	18.5	6.5	5.5	9.0	5	70	30
50	102	69.940 69.866	62	50	G2 1/2" B	13	20.0	8.0	6.5	10.5	6	84	33
key <sup>(a)</sup> See ISO 286-2. <sup>(b)</sup> See ISO 228-1.													

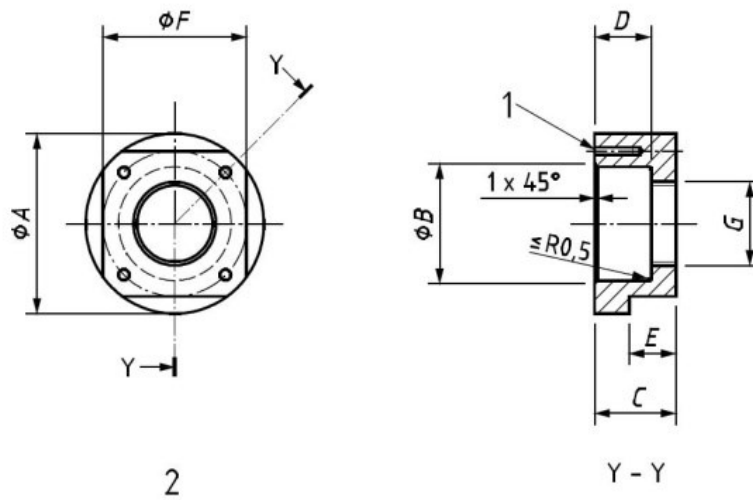

Key

1 4 holes  $\phi H \times J$  deep. Tap K thread  $\times L$

Machined surface roughness  $3.2 \mu\text{m}$  all over

Figure A.4 Body of a threaded type disturbance generator, with dimensions as set out in Table A.2

Table A.2 Dimensions for the body (item 2) of a threaded type disturbance generator

unit : mm

threaded type disturbance generator – item 2 : body												
DN	A	B(H9 <sup>(a)</sup> )	C	D	E	F	G	H	J	K	L	M
15	52	30.052 30.000	23.5	15.5	15	46	G3/4" B	3.3	16	M4	12	40
20	58	36.062 36.000	26.0	18.0	15	46	G1" B	3.3	16	M4	12	46
25	63	42.062 42.000	30.5	20.5	20	55	G1 1/4" B	4.2	18	M5	14	52
32	76	52.074 52.000	35.0	24.0	20	65	G1 1/2" B	4.2	18	M5	14	64
40	82	60.074 60.000	41.0	28.0	25	75	G2" B	4.2	18	M5	14	70
50	102	70.074 70.000	47.0	33.0	25	90	G2 1/2" B	5.0	24	M6	20	84

Key <sup>(a)</sup> See ISO 286-2.

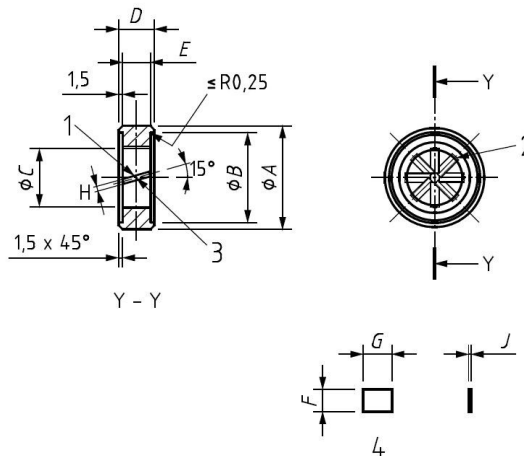

Key

- 1 8 slots equally spaced to locate blades
- 2 locate blades in slots and welding
- 3 depth of slot at centre, 0.76
- 4 blade detail

Machined surface roughness 3.2 µm all over

Figure A.5 Swirl generator for a threaded type disturbance generator

Table A.3 Dimensions for the swirl generator (item 3) of a threaded type disturbance generator

unit : mm

threaded type disturbance generator – item 3 : swirl generator									
DN	A(d10 <sup>(a)</sup> )	B	C	D	E	F	G	H	J
15	29.935 29.851	25	15	10.5	7.5	6.05	7.6	0.57 0.52	0.50
20	35.920 35.820	31	20	13.0	10.0	7.72	10.2	0.57 0.52	0.50
25	41.920 41.820	38	25	15.5	12.5	9.38	12.7	0.82 0.77	0.75
32	51.900 51.780	46	32	19.0	16.0	11.72	16.4	0.82 0.77	0.75
40	59.900 59.780	52	40	23.0	20.0	14.38	20.5	0.82 0.77	0.75
50	69.900 69.780	64	50	28.0	25.0	17.72	25.5	1.57 1.52	1.50

Key <sup>(a)</sup> See ISO 286-2.

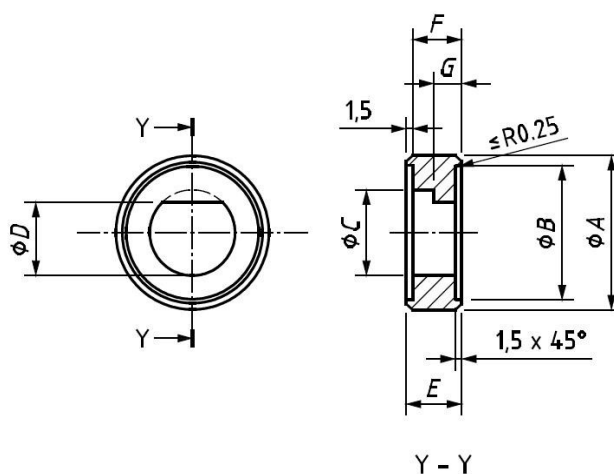

Machined surface roughness 3.2 µm all over

Figure A.6 Flow disturber for a threaded type disturbance generator

Table A.4 Dimensions for the flow disturber (item 4) of a threaded type disturbance generator

unit : mm

threaded type disturbance generator – item 4 : Flow disturber							
DN	A(d10 <sup>(a)</sup> )	B	C	D	E	F	G
15	29.935 29.851	25	15	13.125	10.5	7.5	7.5
20	35.920 35.820	31	20	17.500	13.0	10.0	5.0
25	41.920 41.820	38	25	21.875	15.5	12.5	6.0

32	51.900 51.780	46	32	28.000	19.0	16.0	6.0
40	59.900 59.780	52	40	35.000	23.0	20.0	6.0
50	69.900 69.780	64	50	43.750	28.0	25.0	6.0
Key <sup>(a)</sup> See ISO 286-2.							

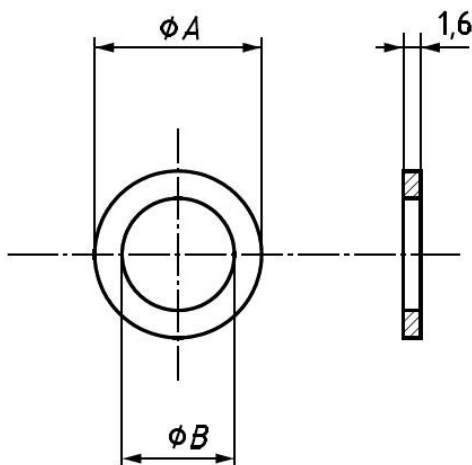

Figure A.7 Gasket for a threaded type disturbance generator

Table A.5 Dimensions for the gasket (item 5) of a threaded type disturbance generator

unit : mm

threaded type disturbance generator – item 5 : gasket		
DN	<i>A</i>	<i>B</i>
15	24.5	15.5
20	30.5	20.5
25	37.5	25.5
32	45.5	32.5
40	51.5	40.5
50	63.5	50.5

A.3 Wafer type disturbance generators

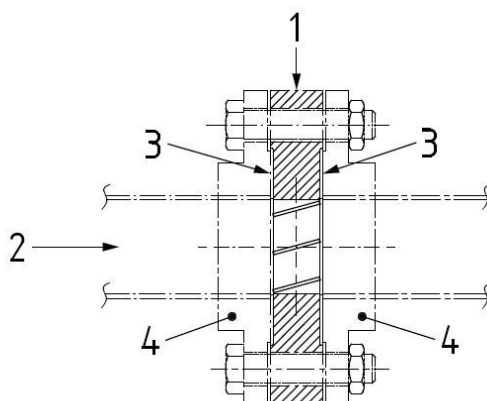

Item	Description	Quantity	Material
1	swirl generator	1	stainless steel
2	flow	—	—
3	gasket	2	fibre
4	straight length with flange (ISO 7005-2 or ISO 7005-3)	4	stainless steel

type 1 disturber – Swirl generator sinistrorsal;

type 2 disturber – Swirl generator dextrorsal

Figure A.8 Wafer type disturbance generators – Arrangement of swirl generator unit

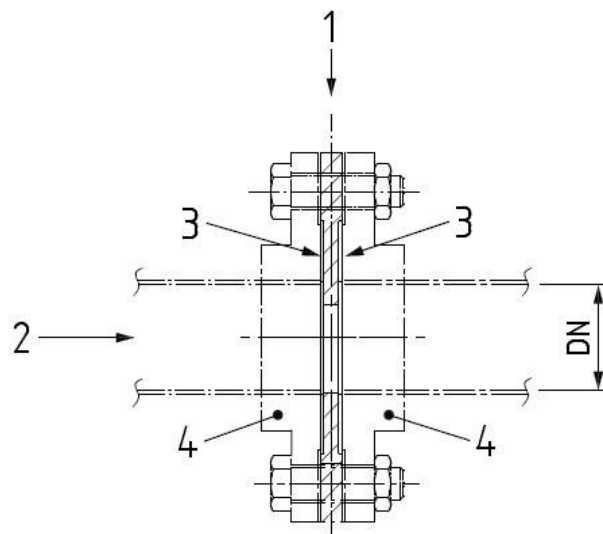

Item	Description	Quantity	Material
1	flow disturber	1	stainless steel
2	flow	—	—
3	gasket	2	fibre
4	straight length with flange (ISO 7005-2 or ISO 7005-3)	4	stainless steel

type 3 disturber – Velocity profile flow disturber

Figure A.9 Wafer type disturbance generator – Arrangement of velocity profile disturbance units

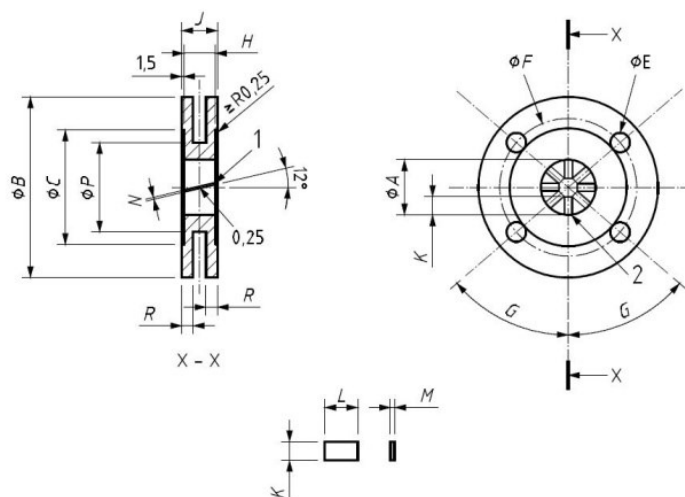

Key

- 1 8 slots equally spaced to locate blades
- 2 blades to be fixed in (welding)
- 3 blade detail

Figure A.10 Swirl generator for wafer type disturbance generator

Table A.6 Dimensions for the swirl generator (item 1) of a wafer type disturbance generator

DN	A	B	C	D	E	F	G	H	J	K	L	M	N	P	R
50	50	165	104	4	18	125	45°	25	28	16.9	25.5	1.5	1.57 1.52	—	—
65	65	185	124	4	18	145	45°	33	36	21.9	33.4	1.5	1.57 1.52	—	—
80	80	200	139	8	18	160	22 1/2 °	40	43	26.9	40.6	1.5	1.57 1.52	—	—
100	100	220	159	8	18	180	22 1/2 °	50	53	33.6	50.8	1.5	1.57 1.52	—	—
125	125	250	189	8	18	210	22 1/2 °	63	66	41.9	64.1	1.5	1.57 1.52	—	—
150	150	285	214	8	22	240	22 1/2 °	75	78	50.3	76.1	3.0	3.07 3.02	195	22
200	200	340	269	8	22	295	22 1/2 °	100	103	66.9	101.6	3.0	3.07 3.02	245	24
250	250	395	324	12	22	350	15°	125	128	83.6	127.2	3.0	3.07 3.02	295	26
300	300	445	374	12	22	400	15°	150	153	100.3	152.7	3.0	3.07 3.02	345	28
400	400	565	482	16	27	515	11 1/4 °	200	203	133.6	203.8	3.0	3.07 3.02	445	30
500	500	670	587	20	27	620	9°	250	253	166.9	255.0	3.0	3.07 3.02	545	32
600	600	780	687	20	30	725	9°	300	303	200.3	306.1	3.0	3.07 3.02	645	34
800	800	1015	912	24	33	950	7 1/2 °	400	403	266.9	408.3	3.0	3.07 3.02	845	36

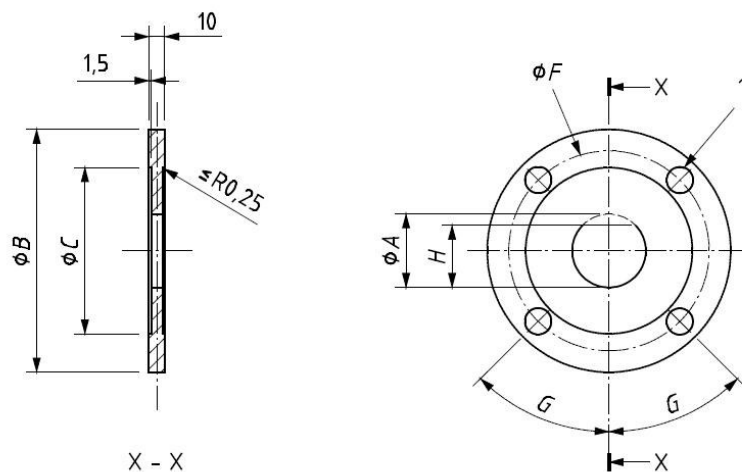

Key

- 1 D holes of  $\phi E$

Figure A.11 Flow disturber of a wafer type disturbance generator

Table A.7 Dimensions for flow disturber (item 2) of a wafer type disturbance generator

wafer type disturbance generator – item 2: flow disturber								
DN	A	B	C	D	E	F	G	H
50	50	165	104	4	18	125	45°	43.8
65	65	185	124	4	18	145	45°	56.9
80	80	200	139	8	18	160	22 1/2°	70.0
100	100	220	159	8	18	180	22 1/2°	87.5
125	125	250	189	8	18	210	22 1/2°	109.4
150	150	285	214	8	22	240	22 1/2°	131.3
200	200	340	269	8	22	295	22 1/2°	175.0
250	250	395	324	12	22	350	15°	218.8
300	300	445	374	12	22	400	15°	262.5
400	400	565	482	16	27	515	11 1/4°	350.0
500	500	670	587	20	27	620	9°	437.5
600	600	780	687	20	30	725	9°	525.0
800	800	1015	912	24	33	950	7 1/2°	700.0

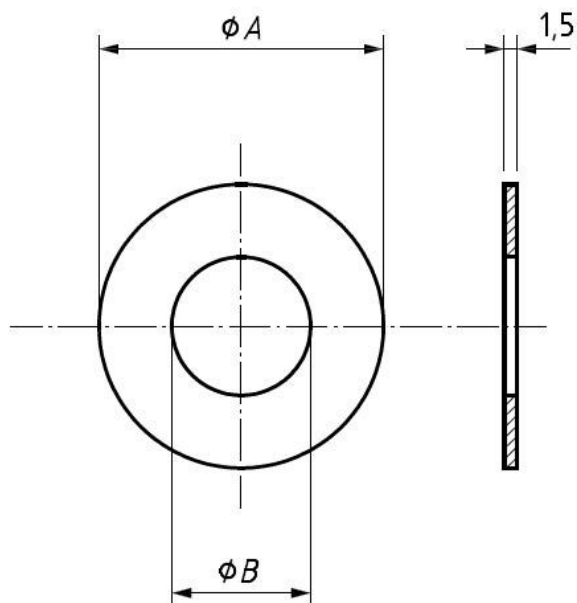

Figure A.12 Gasket of a wafer type disturbance generator

Table A.8 Dimensions for the gasket (item 3) of a wafer type disturbance generator

unit : mm

wafer type disturbance generator – item 3 : gasket		
DN	A	B
50	103.5	50.5
65	123.5	65.5
80	138.5	80.5
100	158.5	100.5
125	188.5	125.5
150	213.5	150.5
200	268.5	200.5
250	323.5	250.5
300	373.5	300.5
400	481.5	400.5
500	586.5	500.5
600	686.5	600.5
800	911.5	800.5



## Appendix B The diameter and overall size of volumetric and velocity meter

### B.1 Diameter and overall dimension

The diameter of water meter is characterized by the thread size of the end connections or by the nominal size of the flange. For each meter size there is a corresponding fixed set of overall dimensions (see Figure B.1). The dimensions are giving in table B.2 and B.3. For thread and connections, two minimum dimensions, a and b, are specified (see B.1.3).

$H_1+H_2$ ,  $L_1$ ,  $L_2+L_3$  define the height, length and width respectively of a cuboid within which the water meter can be contained (the cover being at right angles to its closed position).

$H_1$ ,  $H_2$ ,  $L_1$ ,  $L_2$ ,  $L_3$  are maximum dimensions.

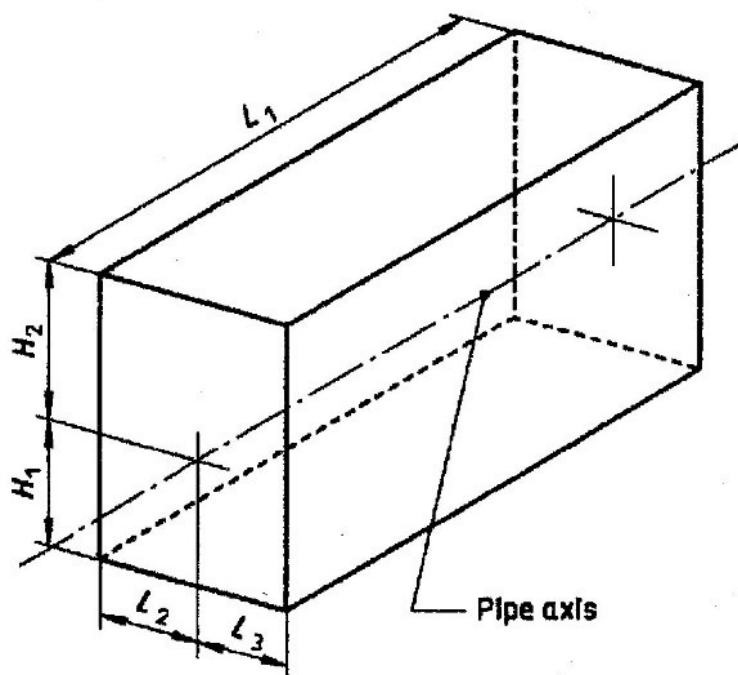

Figure B.1 – Meter size and overall dimension

B.1.1 Permanent flow rate  $Q_3$ , expressed in  $m^3/h$ .

B.1.2 Relationship between meter diameter and meter designation

Meter diameter and hence overall dimensions are in principle linked to the designation of the water meter as specified in Tables B.1 and B.2. For a given meter diameter, it nevertheless is permitted to adopt the immediately adjacent larger or smaller meter diameter, provided that the metrological requirements are met. End connections shall be the same at the water meter inlet and outlet

Table B.1 Water meters with threaded end connections-Meter sizes and dimensions

Meter size		Meter dimensions					
Nominal Diameter DN	Meter diameter (nominal size of threaded end)	$a_{min}$	$b_{min}$	$L_{1max}$	$L_{2max}$ and $L_{3max}$	$H_{1max}$	$H_{2max}$

	connection						
15(13)	G 3/4 B <sup>(3)</sup>	10	12	165	50	40	100
20	G 1 B <sup>(3)</sup>	12	14	190	65	40	100
25	G 1-1/4 B <sup>(3)</sup>	12	16	210	85	45	110
40	G 2 B <sup>(3)</sup>	13	20	245	85	50	140
50	G 2-1/2 B <sup>(3)</sup>	13	20	270	115	60	180
(3) thread size of the next larger value is accepted as an alternative.							

Table B.2 – Water meters with flanged end connection – Meter designations, meter sizes and dimension

Meter size		Meter dimension (unit: millimeters)									
		L <sub>1max</sub>		L <sub>2max</sub> and L <sub>3max</sub>				H <sub>1max</sub>		H <sub>2max</sub>	
DN (1)	Size	Volumetric, single-jet and multi-jet	Woltmann	Volumetric, single-jet and multi-jet	Woltmann	Volumetric, single-jet and multi-jet	Woltmann	Volumetric, single-jet and multi-jet	Woltmann	Volumetric, single-jet and multi-jet	Woltmann
			Vertical axis	Horizontal axis	Vertical axis	Horizontal axis	Vertical axis	Horizontal axis	Vertical axis	Horizontal axis	
50	350	350	560	200	135	135	135	135	140	100	390
65	450	450	-	300	150	-	135	135	-	110	39
75	480	480	630	200	170	135	135	135	170	120	410
100	650	650	750	250	225	135	135	135	180	140	440
125	-	-	-	250	-	-	135	135	-	140	440
150	-	-	1000	300	-	180	175	175	220	180	500
200	-	-	1160	350	-	225	190	190	255	200	500
250	-	-	1240	450	-	250	210	210	270	220	500
300	-	-	1600	500	-	290	240	240	2850	250	500

Note: (1) Nominal size of flange end connections.

### B.1.3 Threaded connection

Values are given in table B.1. Threads shall comply with CNS 494. Figure B.2 defines dimensions a and b. When there is installation problem for replacing new water meter, the threads specified in Section B.2 may be adopted.

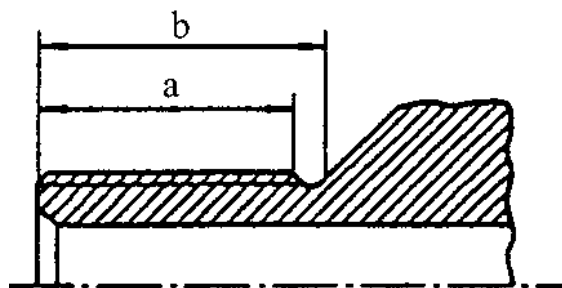

Figure B.2 - Thread

### B.1.4 Flanged connection

Either one of the following specification of flange shall be adopted.

B.1.4.1 Flanged end connections shall comply with table A.2 for working pressure 0.735 MPa of CNS 12795 or CNS 13272, and the flange size is in accordance with the provisions of Table 2 of CNS 12795. The manufacturer shall provide a reasonable clearance behind the rear face of the flange to allow access for installation and removal.

B.1.4.2 The flange connection end face adopts the flange size of other specifications of working pressure. However, the applicant shall provide the connection adaptor for type approval testing. The manufacturer shall provide a reasonable clearance behind the rear face of the flange to allow access for installation and removal.

## B.2 The thread specification of threaded connecting of water meters.

### B.2.1 Type

The thread type of threaded connecting of water meters are divided into two types, male pipe thread and female pipe thread.

### B.2.2 Dimension

The dimension of thread is described in Table B.3, the basic profile of and basic dimension is described B.4 and the tolerance of dimension is described in Table B.5.

Table B.3 Dimension of thread of water mete

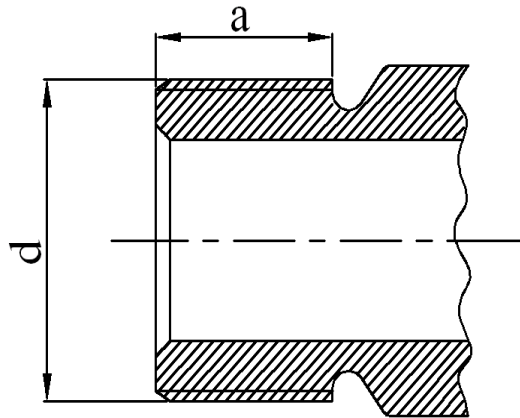

Nominal Diameter (unit: mm)	Outside diameter of water meter d (unit: mm)	Number of Threads per 25.4 mm	a (minimum) (unit: mm)
15(13)	25.8	14	14
20	33.0	14	14
25	39.0	14	14
4.	56.0	11	18
50	67.6	11	18

Table B.4 Thread profile

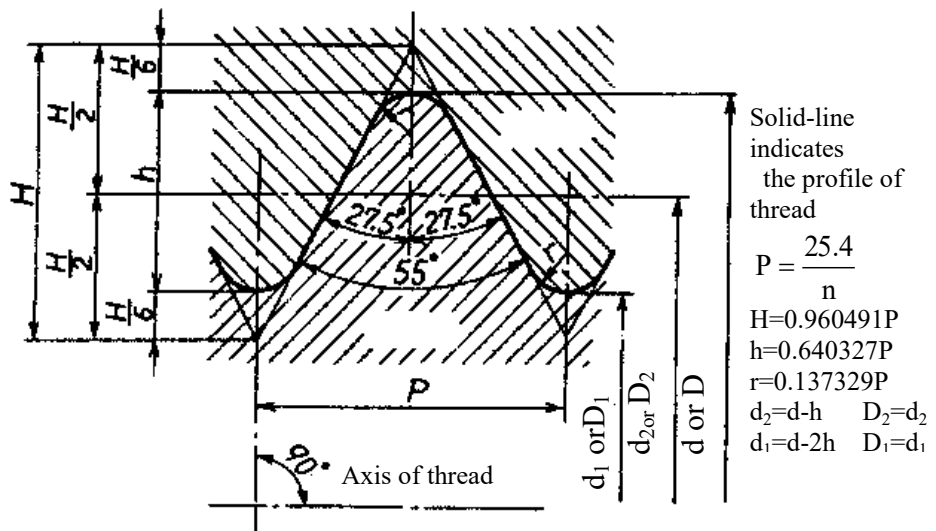

Nominal Diameter (unit: mm)	Number of Threads per 25.4 mm	Pitch (unit: mm)	Height of thread	Radius of rounded crests and roots	Diameters of external thread (unit: mm)		
					Major d	Pitch $d_2$	Minor $d_1$
					Diameters of internal thread (unit: mm)		
Major D	Pitch $D_2$	Minor $D_1$					
15(13)	14	1.8143	1.162	0.25	25.8	24.64	23.48
20	14	1.8143	1.162	0.25	33.0	31.81	30.68
25	14	1.8143	1.162	0.25	39.0	37.84	36.67
40	11	2.3091	1.479	0.32	56.0	54.52	53.04
50	11	2.3091	1.479	0.32	67.6	66.12	64.64

The basic profile of threads in this table is according to CNS 494

Table B.5 Deviation of dimension

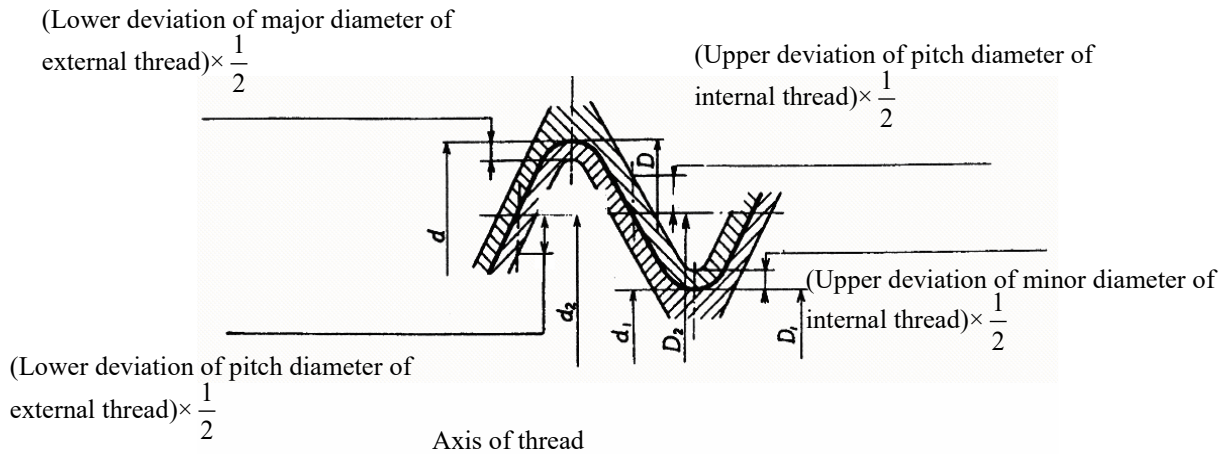

A: external thread

B: internal thread

Nominal Diameter (unit: mm)	Number of Threads per 25.4 mm	Tolerance on the pitch of external thread (unit: $\mu\text{m}$ )						Tolerance on the pitch of internal thread (unit: $\mu\text{m}$ )					
		Major d		Pitch <sup>(1)</sup> $d_2$		Minor $d_1$		Major D		Pitch <sup>(1)</sup> $D_2$		Minor $D_1$	
		Upper deviation	Lower deviation (-)	Upper deviation	Lower deviation (-)	Lower deviation	Upper deviation	Lower deviation	Upper deviation	Lower deviation	Upper deviation (+)	Lower deviation	Upper deviation (+)
15(13)	14	0	284	0	284	0	No specified	0	No specified	0	142	0	541
20	14	0	360	0	360	0		0		0	180	0	640
25	14	0	360	0	360	0		0		0	180	0	640
40	11	0	360	0	360	0		0		0	180	0	640
50	11	0	434	0	434	0		0		0	217	0	640

Note: <sup>(1)</sup> For thin-walled parts, the tolerances apply to the mean pitch diameter, which is the arithmetical mean of two diameters measured at right angles to each other.

1. The deviations specified in this table are according to B Class of CNS 494.
2. The deviations of half angle of thread and the pitch dimension that not specified in this table have been converted into diametral pitch and included in the tolerance of pitch.

### Annex C Vortex water meter diameter and shape dimensions

#### C.1 Diameter and overall size of meters

The structure of meters are described as Figure C.1, the overall size and flow-rates are described as Table C.1. Unspecified structure and dimension mat be decided by manufacturers.

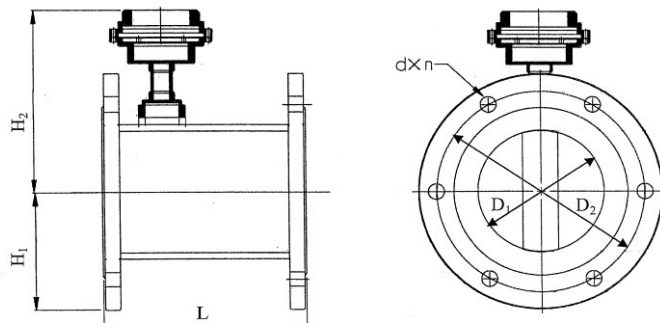

Figure C.1 The flange dimension of Vortex water meters

Table C.1 – The flow-rate and dimension of vortex meters

Specification Nominal Diameter (DN) (unit: mm)	Vortex water meters				
	Maximum flow-rate (m <sup>3</sup> /h) ≥	Minimum flow-rate (m <sup>3</sup> /h) ≤	L (unit: mm) ≤	Button to Center of Bore(H <sub>1</sub> ) (unit: mm) ≤	Top to Center of Bore(H <sub>2</sub> ) (unit: mm) ≤
50	60	6	170	100	390
75	160	16	190	120	410
100	250	25	210	140	440

Note 1. The flow-rates listed in the table are based on the working medium (water) with dynamic viscosity  $1 \times 10^{-6} \text{ m}^2/\text{s}$ .

2. The dimension D<sub>2</sub> and d x n of the flanges are specified in CNS 12795 or CNS 13727.